



AMIGO OPERATIONAL MANUAL

RT, RD, and HD

Read this manual before operating your Amigo

Amigo RT



Amigo RD



Amigo HD



Serial Number: _____

Date of Purchase: _____

TABLE OF CONTENTS

Safety First	3
Location of Controls	4
Adjusting Your Amigo	5
Operating Your Amigo	6-7
Helpful Hints for Everyday Use	7-8
Battery and Charging Information	9-10
Cleaning Instructions	11
Maintenance	11-12
Troubleshooting	13-14
Electromagnetic Interference	15
Wiring Diagrams	16-20
Exploded Views and Parts Lists	21-26
Amigo Mobility Healthcare Warranty	27

Amigo RT



Amigo RD



Amigo HD

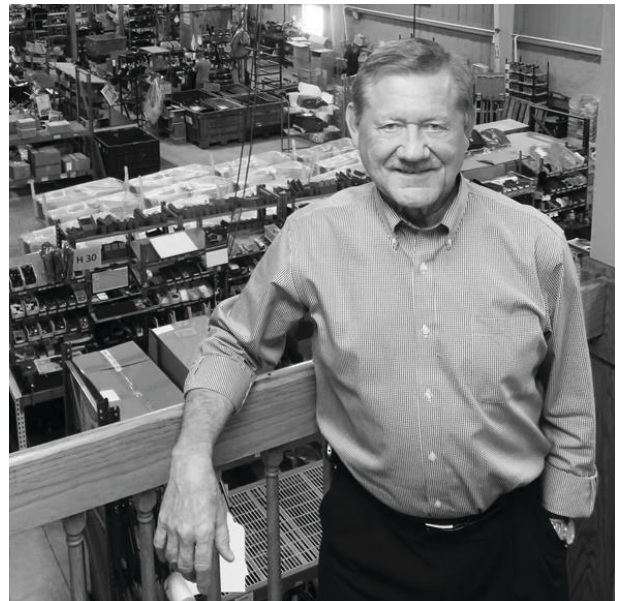

More than 50 years ago in Bridgeport, Michigan, Al Thieme was working as a plumbing and heating contractor when a family member began to lose mobility due to multiple sclerosis.

Witnessing this loss of independence, Al knew there must be a better way. After countless evenings spent working in his garage, he invented the first-ever power-operated vehicle, the Amigo. Consequently, Amigo Mobility International, Inc. was founded, and an entire industry was born.

As Amigo's Chairman and Founder, Al Thieme continues to run the company daily. Hands-on and focused, he is passionate about *Improving Lives Through Mobility®*. Today, all Amigos are manufactured in Bridgeport, Michigan, and are shipped worldwide.

We would like to thank you for choosing Amigo. We are committed to providing you with personalized, innovative electric mobility products and customer satisfaction today and into the future. Wishing you happiness and good health from all of us at Amigo.

Sincerely,

Amigo Mobility International, Inc. (AMI)



Amigo Mobility International, Inc. (AMI) disclaims any responsibility for personal injury or property damage resulting from the improper or unsafe use of its products.

SAFETY FIRST

For your convenience and understanding, signal words are defined below:



WARNING IS USED TO INDICATE THE PRESENCE OF A HAZARD, WHICH CAN CAUSE SEVERE PERSONAL INJURY, DEATH, OR SUBSTANTIAL PROPERTY DAMAGE IF THE WARNING IS IGNORED.



CAUTION IS USED TO INDICATE THE PRESENCE OF A HAZARD WHICH WILL OR CAN CAUSE MINOR PERSONAL INJURY OR PROPERTY DAMAGE IF THE CAUTION IS IGNORED.

AMI is not responsible for any damage or injury incurred due to improper or unsafe use of the POV. AMI specifically disclaims responsibility for any bodily injury or property damage that may occur during any use which does not comply with applicable federal, state, or local laws or ordinances. Use the following guidelines for safe operation and use of your Amigo. Please contact Amigo with questions about safe operation of your Amigo. Consult your personal physician with questions on your ability to operate your Amigo.

Do

- Read the operating manual before using your Amigo.
- Always turn the key switch off before getting on or off your Amigo.
- When transferring on or off your Amigo, make sure the seat lock is in the locked position.
- Always remain seated while the vehicle is in operation.
- Keep your legs on the platform while driving.
- Drive to a complete stop in forward before attempting to reverse. Also, a complete stop in reverse before attempting to go forward
- Always drive in a slow, sensible manner.
- Drive slowly while turning and on inclines.
- Always drive straight up and down inclines.
- Always be careful when maneuvering on inclines or ramps. Not all ramps are constructed according to federal standards. The federal standard for wheelchair ramps is 1 inch (2.5 cm) rise per foot (30 cm).
- Avoid sudden starts, accelerate gradually.
- Always approach obstacles at a low speed if you are to drive over them.
- Be aware of mechanical pinch points, especially when assembling and disassembling your Amigo.
- Always drive with the power seat lift in its lowest position.
- Always lock seat during vehicle operation.

Do Not

- Do not exceed the maximum weight capacity. Exceeding the weight capacity voids your warranty and may result in personal injury and damage to your Amigo. Amigo will not be responsible for injuries and/or property damage resulting from failure to observe weight limitations.
- Do not drive over or off obstacles more than 1 inch (2.5 cm) high. This could be unsafe and could damage your Amigo.
- Do not turn your Amigo at high speeds, as this could result in tipping.
- Do not reverse down or park on a steep hill or incline.
- Do not sit on the unit in a moving vehicle.
- Do not allow anyone to ride with you.
- Do not operate your Amigo near stairs, steps, curbs, or terraces where you might accidentally drop a wheel off the edge.
- Do not operate your Amigo on streets or other areas with vehicular traffic.
- Do not disengage the brake on a slope.
- Do not leave the brake release in freewheeling position.
- Do not disengage the brake while someone is on the vehicle.
- Do not remove handle from steering column when transporting your Amigo. Instead, fold the handle down to the seat. Place the handle down so the controls will not be damaged. Tighten the knob to secure the handle.
- Do not use the handle to assist in transferring on or off the Amigo.
- Do not lift rear section of platform by holding the rear wheel.
- Do not push or force the retractable cord reel into the rear cover.
- Do not remove the ground wire (shown on pages 16-18), as it aids in static discharge.

LOCATION OF CONTROLS

1. Accelerator lever (left and right)
2. Battery status gauge
3. ON/OFF key switch
4. Rabbit button – press to increase top speed
5. Turtle button – press to decrease top speed
6. Brake release button – press twice
7. Speed gauge – indicates level of top speed
8. Power seat lift (PSL) UP button – press to raise seat
9. Power seat lift (PSL) DOWN button – press to lower seat
10. Front headlight and rear taillights button
11. Horn button
12. Forward and reverse diagrams for accelerator levers

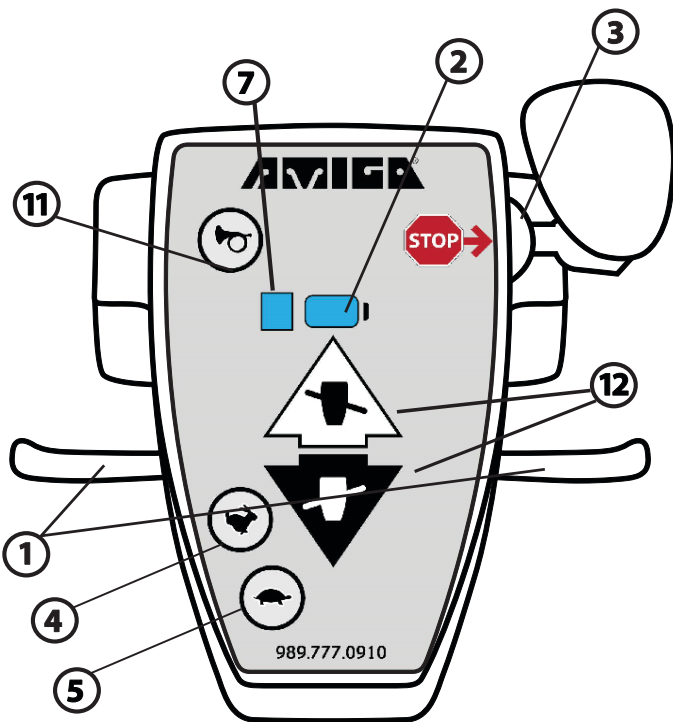

Figure 1
(HI/LO)

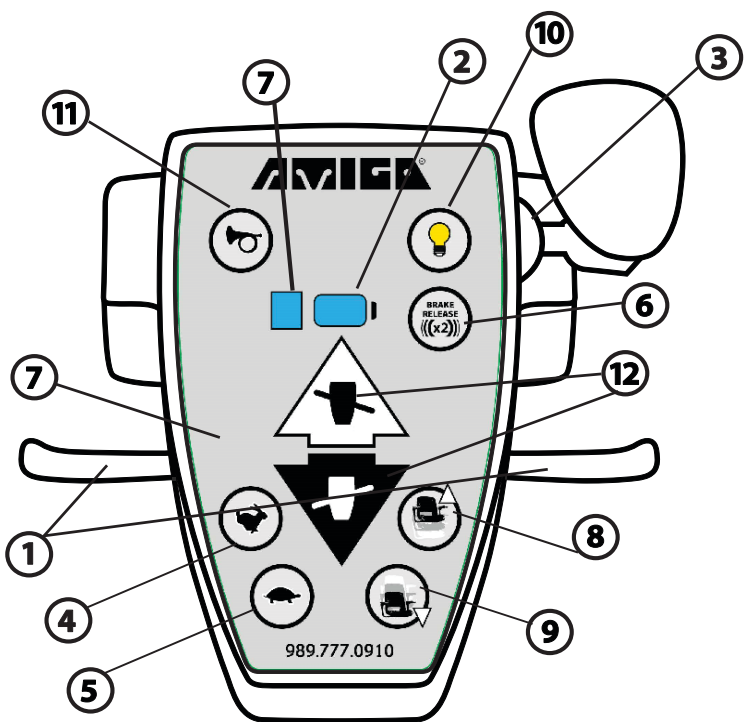

Figure 2
(TouchTron)

Hi/Lo Speed Adjustment Handle (Figure 1)

Handle controls include: speed adjustment buttons, ON/OFF key switch, battery status gauge, speed level gauge, and horn button. The ON/OFF key switch, located on the right side of the handle control cover, will turn the power of the Amigo on or off. Turning off the Amigo will prevent drainage of batteries and unauthorized use. Every time a button is activated on the touchpad, you will hear a “chirp.”

TouchTron Handle (Figure 2)

Handle controls include: speed adjustment buttons, ON/OFF key switch, battery status gauge, speed level gauge, horn button, brake release, turn indicator lights, headlight/taillights, and power seat lift adjustment buttons. The ON/OFF key switch, located on the right side of the handle control cover, will turn the power of the Amigo on or off. Turning off the Amigo will prevent drainage of batteries and unauthorized use. Every time a button is activated on the touchpad, you will hear a “chirp.”

ADJUSTING YOUR AMIGO

To adjust your Amigo to a comfortable driving position, you can alter the handle, seat, and armrests as follows:

EZ-Tilt Handle Adjustment

To adjust the angle of the handle, turn the adjustment lever counterclockwise. Move the handle to the desired position. Tighten the adjustment lever by turning it clockwise (Figure 3). The placement of the spring-activated adjustment lever can be moved out of the way for your comfort. Pull the adjustment lever straight out. Turn in either direction. Release adjustment lever at desired placement (Figure 4).

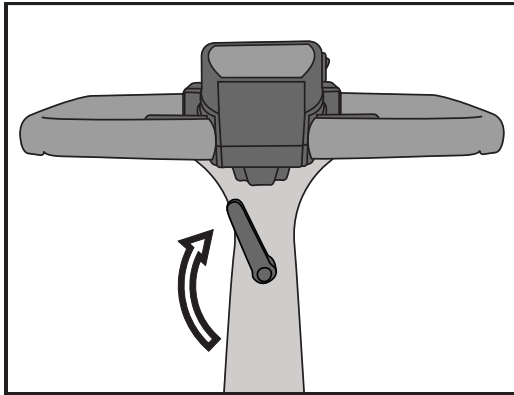

Figure 3

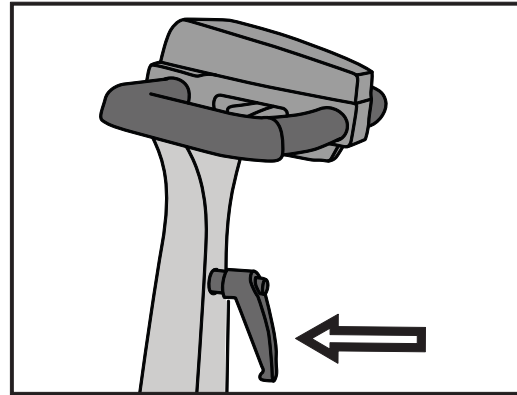

Figure 4



CAUTION

DO NOT USE THE ADJUSTMENT LEVER AS A FOOT REST. SUCH USE MAY CAUSE THE ADJUSTMENT LEVER TO LOOSEN THE HANDLE AND CAUSE PERSONAL INJURY.

Seat Installation

1. Unlock the seat lock.
2. Insert the upper seat post into the opening of the lower seat post.
3. Spin seat around to make sure it rotates freely.
4. To lock the seat, pull the seat lock lever toward the rear of the seat.

Adjusting Seat Height Without a Power Seat Lift

To adjust seat height, remove the nut and screw that holds the seat collar in place on the seat post, then adjust and reinstall in the desired hole on the seat post (Figure 5).

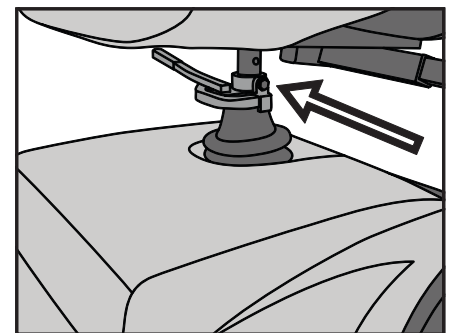

Figure 5



CAUTION

IT IS RECOMMENDED THAT THE SEAT LOCK BE INSTALLED IN THE SECOND HOLE POSITION FROM THE SEAT ON A FOLDING SEAT AND THE PREMIER II SEAT.

Seat Lock Lever

This allows the seat to rotate 360 degrees and lock in any position desired. The seat lock lever is a bar with a vinyl cap on its end, located under the seat (Figure 6). Push the lever forward to rotate to any position. Lock seat during vehicle operation.

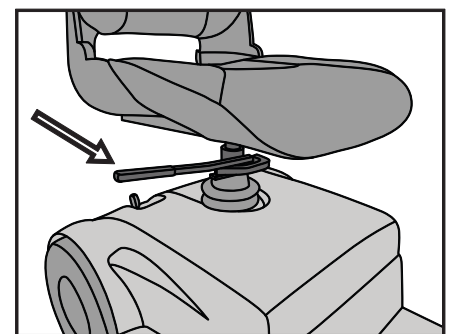

Figure 6

Adjustable Armrest Width

The armrest width is determined by loosening the armrest knobs and tightening them when the arms are at the desired width.

Flip-Up Armrest

By pulling up on the end of either armrest, the armrest will flip back for easy transfer in and out of the Amigo.

OPERATING YOUR AMIGO

To operate your Amigo, use the following procedures:

Turning On and Driving Your Amigo

- For all Amigo rear drive models, the key switch is located on the top of the handle. Insert and turn the key provided.
- Regulate your maximum speed with the rabbit and turtle buttons. To increase the top speed, press the rabbit button. To lower the top speed, press the turtle button. You may have to press the turtle or rabbit button several times to see a change on the speed gauge. Continuous “chirping” sounds indicate highest and lowest speed settings.
- Press the forward accelerator lever or the reverse accelerator lever to move the Amigo. To move forward, pull the right side of the accelerator lever toward you (Figure 7). You can also move forward by pushing the left side of the accelerator lever away from you. To operate in reverse, pull the left side of the accelerator lever toward you (Figure 8) or push the right side of the accelerator lever away from you.
- For optional “reverse polarity” handles, accelerator lever operation will be the opposite. To move forward, pull the left side of the accelerator lever toward you or push the right side accelerator lever away from you. To move in reverse, pull the right side of the accelerator lever toward you or push the left side accelerator lever away from you.
- To stop, release the accelerator lever and the vehicle will come to a gradual stop. Turning the Amigo off using the key switch may be used for emergency stops.
- The horn button should be used to avoid confrontation with pedestrians or other mobile entities.
- When the Amigo is used at night, you can turn the lights on by pressing the light button (TouchTron only).

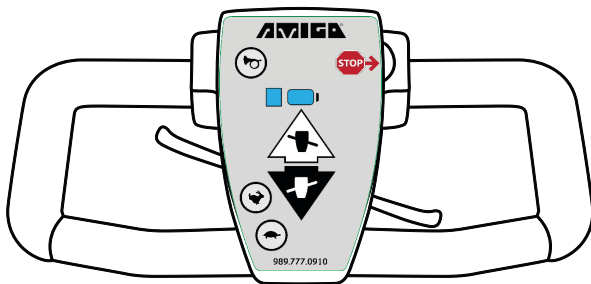

Figure 7 (forward)

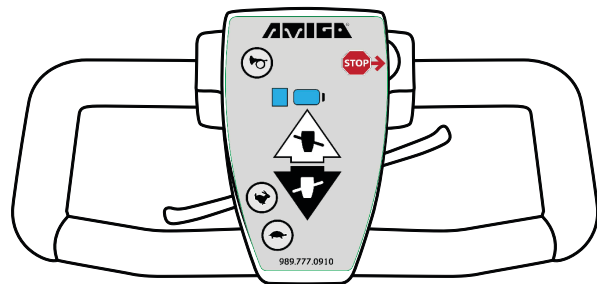

Figure 8 (reverse)

Brake Release for Manual Pushing

All models are equipped with a manual brake release lever. To engage the freewheeling mode, push the brake lever forward. The freewheeling mode will allow you to push the unit if necessary. To terminate the freewheeling mode, pull the brake lever toward the rear of the Amigo (Figure 9). When pulled into “normal,” the vehicle will be back in “drive” mode.

Models with TouchTron controls have an additional brake release button located on the handle (Figure 10). To electronically release the brake, push the brake release button twice. The low-speed segment of the speed gauge will blink to indicate you are now in the freewheeling mode. To terminate the freewheeling mode when selected electronically, activate any control button (except horn button) on the TouchTron handle, or pull the accelerator lever.

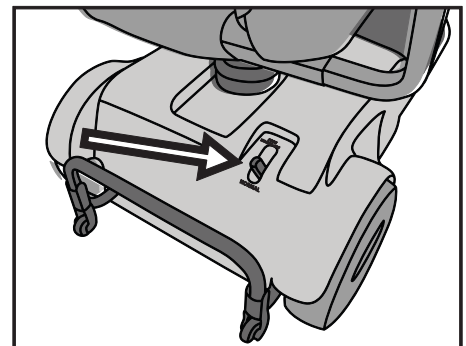

Figure 9

Sleep Mode

A battery indicator and diagnostic system are incorporated into the touchpad of all Amigo rear drive models. The battery status gauge will be lit whenever the key is in the ON position. However, if the Amigo is inactive for more than 25 minutes, the Amigo automatically switches to “sleep mode.” This feature reduces power to conserve the battery range. To reactivate your Amigo, switch it off and then on again to regain full function. It is recommended that you turn the key to the OFF position each time you are through using the Amigo to ensure the power is completely turned off.

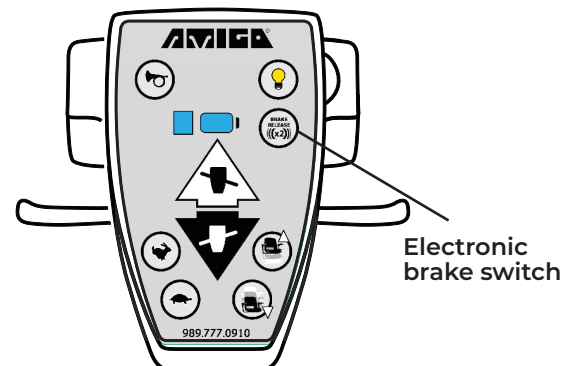

Figure 10

Power Seat Lift Operation (Optional)

To operate the power seat lift on Amigo models with a TouchTron handle, press the seat/directional arrow buttons to raise or lower the seat (Figure 11). To lift the seat to the desired height, press the seat button with the arrow pointing up. To lower the seat, press the seat button with the arrow pointing down. The power seat lift can be activated only when you are not moving. Always drive with the power seat lift in its lowest position.

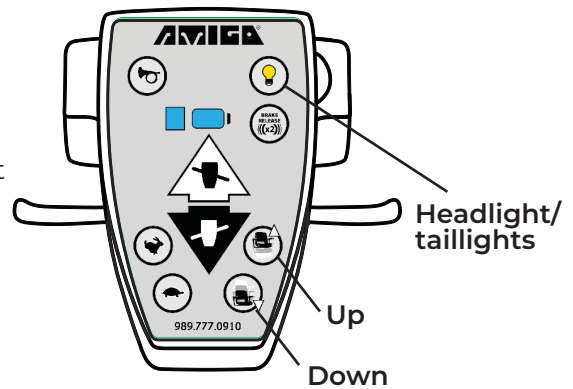

Figure 11



CAUTION

TO AVOID DAMAGING THE MOTOR OF THE POWER SEAT LIFT, RELEASE THE SEAT BUTTON AFTER THE SEAT HAS REACHED ITS HIGHEST OR LOWEST POINT.

LED Light Package Operation (Optional)

The optional lighting package available with the TouchTron handle includes a front headlight and rear taillights. The power must be on to operate the headlight or taillights. The headlight and taillights can be activated by pressing the headlight button (Figure 11). Press this button again to turn the lights off.

RIDING YOUR AMIGO

Basic Driving

Be sure you are on a level surface. Once seated, for safe transfer or driving, push seat lock lever (located under seat) forward to easily position the seat as needed. Engage lever back to the locked position.

- Make sure you are properly seated and insert key into key switch and turn counterclockwise to the ON position.
- Ensure the speed adjustment gauge is at the lowest setting. Note that reverse movement of vehicle may not occur with speed adjustment at lowest setting.
- On handle, gently pull the accelerator lever as described earlier. You will gently accelerate. The further you pull the accelerator lever, the faster you will go. Release the lever and you will gently stop. Reverse speed is slower than forward speed. Practice these two basic functions until you get used to them.
- Steering the Amigo is easy and logical. Just be sure to remember to give wide clearance when turning so that the rear wheels clear any obstacle.
- Shortcutting a sidewalk corner can cause the back wheel to go off the sidewalk. Avoid this at all times by steering an exaggerated wide arc around the obstacle. If you must steer in a tight spot, such as entering a doorway or when turning around, stop and then apply power gently. For more on maneuvering through obstacles, see the next section.

Driving Through Doorways

Approach an unfamiliar door slowly. Does it have a knob or push bar? Does it open toward or away? Think in terms of using the power of the Amigo to do the work for you. Hold the doorknob or bar in one hand and apply the power with the other hand. If it is a self-closing door, you can go through allowing the door to close behind you. If it is not a self-closing door, just stop when you are clear of the door and push it closed. If the door opens toward you, hold the knob or bar with one hand and gently press on your reverse accelerator lever and allow the gentle reverse power to do the work. When the door is open wide enough, pull the forward accelerator lever to move forward, leaving your hand on the door to keep it free of the Amigo and letting go as you pass the door jamb.

Driving on Ramps

With the ADA (Americans with Disabilities Act), buildings require ramps for POV (power-operated vehicle) access. Some have U-turns in the middle where good cornering is required. Take wide swings with your front wheels around any tight corners so the rear wheels follow a wide arc to stay clear of the corner. When you have stopped while facing uphill, starting up again simply requires that you apply forward power. Accelerate gently after stopping on an incline. When proceeding up a ramp or curb, lean forward in your seat for maximum stability and safety. Going down any ramp or hill, drive slowly to ensure a safe descent.

Driving Over Grass, Gravel, and Grades

The Amigo performs admirably in grass, gravel, and on hills, but you must NOT exceed the parameters set down in this manual. Please refer to the safety suggestions for use. Safety must come first. If you are unsure about any situation, avoid it. Common sense is your best protection. Always act with caution. Feel free to use your Amigo on lawns or in park areas. Avoid long, unkempt grass; otherwise, just follow the safety suggestions.

Transport

Amigos are NOT designed or tested for use as seats for users in private or public transporting vehicles. AMI advises against transporting POVs in vehicles unless the unit is dismantled and placed in the trunk of a vehicle or the assembled unit is placed in the vehicle and strapped down. Any straps should be secured to non-removable parts of the unit, such as the platform. Even when strapped down, Amigos should not be used as seats in private or public transporting vehicles.

How to Disassemble and Transport Your Amigo:

1. Turn your Amigo off.
2. Unlock the seat and remove it completely.
3. Remove the batteries by removing the rear cover and using quick disconnect tabs.
4. Fold the handle down to the platform by loosening the handle adjustment knob.
5. Lift the rear into the trunk of the vehicle and slide the rest of the Amigo into the trunk.
6. To prevent wheels from rotating when batteries are removed, the brake release lever must be in the "normal" position.
7. Place the seat and batteries into the trunk.
8. If your Amigo has a power seat lift, we suggest placing a cut-out tennis ball or something similar over the seat post to protect it.

Airline Travel

Special handling tags are suggested when transporting your Amigo by air. Visit the Healthcare Service webpage on www.myamigo.com for a pre-designed tag (Figure 12). Non-spill, sealed batteries are approved for commercial airline travel by the Civil Aeronautics Board (CAB). When you make your reservation, notify the airline and request escort assistance. This will ensure that your Amigo will be picked up and delivered at the boarding desk. For additional helpful hints for airline travel, visit our website at www.myamigo.com.

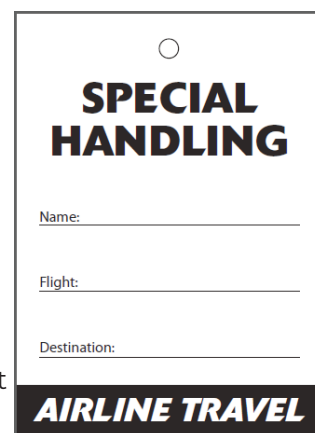

A rectangular tag with a white background and a black border. At the top center is a small circle. Below it, the words "SPECIAL HANDLING" are printed in large, bold, black capital letters. Underneath, there are three horizontal lines for text, each preceded by a label: "Name:", "Flight:", and "Destination:". At the bottom of the tag, there is a black horizontal bar with the words "AIRLINE TRAVEL" in white, bold, italicized capital letters.

Figure 12

Public Transportation

Some public transportation systems have accommodations for your Amigo. If you must utilize public transportation, do not sit on the Amigo while the vehicle is in motion. Transfer to the transporting vehicle seat.



WARNING

WHEN TRANSFERRING OR NOT USING THE AMIGO, WE RECOMMEND TURNING THE AMIGO TO THE OFF POSITION.

Bathroom

In the bathroom, maneuvering room is usually limited. Back into bathroom, then position close to the toilet, swivel the seat, lock it in position and transfer. When using the bathtub, back up parallel to the tub. Swivel the seat and place your feet in the tub. Engage seat lock and carefully transfer.



WARNING

DO NOT USE YOUR AMIGO WHILE TAKING A SHOWER. WATER MAY GET INTO THE MICROPROCESSING CONTROLLER (MPC) AND CAUSE ELECTRONIC MALFUNCTIONS.

Bedroom

To transfer to the bed, back up parallel to it. Swivel, lock seat into position and ease onto the bed. If charging the batteries overnight, it may be easiest to plug in the battery charger before transferring. For added ease, when using a power seat lift, raise your seat slightly higher than the surface to which you are transferring.

Kitchen

For access to a refrigerator, make a parallel approach or back up to the outside of the refrigerator. Swivel the seat. Approach a table, sink, or stove by maneuvering parallel to it. Swivel the seat to the desired position. The handle will be out of the way.

Car

To transfer to a car, make a parallel approach to the side of the car, release the door latch, and open the door as you drive forward. Back parallel to the side of the car and into the door opening. Swivel the seat, lock it in position and carefully slide onto the car seat. On the driver's side, you can use the steering wheel for leverage.

Using an Elevator

Backing into an elevator allows you to exit forward. Be sure the elevator is level with the floor.

BATTERY AND CHARGING INFORMATION

Battery Information

For maximum range and life, it is recommended to fully charge the batteries before using. Extended charging is good for the batteries and will not overcharge them. Amigos have an overcharge protection feature so that the batteries can be charged anytime the Amigo is not being used. It is a popular misconception that batteries should be deeply discharged before recharging. This is not the proper procedure for all batteries. They can actually be damaged if they are discharged too deeply before recharging.

Battery range can be affected by many variables, including driver weight, terrain, temperature, and battery age and type. Charge your batteries daily when the Amigo is used. Make sure that the charger cord is unplugged from the wall outlet before moving your Amigo.

Batteries should be charged if the leftmost segment bar on the battery status gauge is lit and blinking and the horn is making a low, chirping noise at one-minute intervals. At the beginning of the charging process, the battery indicator light on the handle will flash for approximately 20 seconds, then it will turn solid color. The batteries are fully charged when the bar on the far right is blinking. Your Amigo can be charged with the key in the ON or OFF position. The indication will display only while in the charging mode (when power cord is plugged into AC outlet).

Charging Instructions for Amigo RT, RD, and HD

1. Place your Amigo near an AC outlet.
2. Pull gently on the cord reel plug in the rear cover near the rear bumper.
3. Pull as much cord as needed (up to 10 feet/3 meters) to reach the AC outlet.
4. Connect the cord reel plug to the AC wall outlet.
5. Upon completion of the charging process, unplug the cord reel plug from the AC wall outlet.
6. Gently tug on the cord to engage the retraction reel. Do not push cord into the hole in the rear cover.

Charging Frequency

- Charge batteries daily when the Amigo is used.
- If it has not been in use for a long period of time, charge for 24 hours every 30 days.
- Extended charging is good for the batteries and will not overcharge them.

Universal Charger Option

A universal charger is available on many Amigos sold outside the United States. The universal charger uses a range of 90-240 volts AC power input. This makes it possible to charge on any electrical system globally. (The universal charger is an option on models in the U.S. for people who travel abroad and want this universal charging flexibility.) Your charger is labeled, identifying which charging system it uses.



DO NOT USE A 24V CHARGER THAT IS CONFIGURED TO A 120V AC POWER INPUT OUTSIDE THE U.S. IN COUNTRIES USING 220V AC POWER INPUT. DAMAGE WILL OCCUR TO THE CHARGER.

Charging Standard Precautions

- Charge batteries fully in a dry location.
- Clean any corrosion on the plug.
- Examine cord periodically for cracking or damage.
- If you remove the batteries from the Amigo, place them on a surface resistant to damage by acid fumes.
 - Whenever a battery is charged and discharged through a cycle, it breathes. The breathing of the battery emits acid fumes into the cloth strap (used to lift the batteries on rear drive models) and may mark surfaces it rests on for long periods of time. Store batteries indoors in a dry environment, away from any open flames. Temperature range is 0 °C (32 °F) to 40 °C (104 °F).
- Each time you charge the Amigo, follow the charging instructions exactly. Working in the vicinity of a sealed lead-acid battery can be dangerous. Batteries can generate explosive gases during normal battery operation.
- Never smoke or allow an open flame in the vicinity of the batteries.
- Use only a charger designed for sealed lead-acid batteries. The charger is not intended to supply power to an extra-low voltage electrical system or to charge dry-cell batteries.
- Never charge a frozen battery. Let set in above freezing temperatures for several hours before charging.
- Do not operate the charger in a closed-in area or restrict ventilation in any way.
- A spark near the battery may cause an explosion. To reduce the risk of spark:
 - Prevent external damage to AC and DC cords.
 - Connect DC charging cord to the charge plug before connecting charger AC supply cord to the AC electrical outlet
 - When disconnecting the charger, always do so in reverse sequence of connecting procedure. Break first connection as far away from battery as practical. Distance reduces the chance of explosion if a spark is generated and gas is present.
- Someone should be within range of your voice or close enough to come to your aid if needed.
- Be extra cautious not to drop a metal tool onto the batteries.
- Remove metal jewelry before servicing batteries.



CAUTION

FAILURE TO FOLLOW THESE SAFETY INSTRUCTIONS MAY RESULT IN PERSONAL INJURY OR PROPERTY DAMAGE.



WARNING

IF YOUR BATTERIES ARE DAMAGED AND A LEAK IS APPARENT, CALL YOUR AUTHORIZED DEALER IMMEDIATELY. UNDER NO CIRCUMSTANCES SHOULD YOU TOUCH THE BATTERIES IF THEY ARE LEAKING.

Battery Storage

All the Amigo rear-drive models use a battery system that allows the batteries to be removed after they have been disconnected from the platform battery connections. Each battery has a wire assembly with a two-position connector that plugs into the connector mounted to the platform. The connection system is designed so that either battery may be placed on either side of the unit. Always turn your Amigo off before removing and installing batteries.



WARNING

TO AVOID DAMAGE TO BATTERIES DURING STORAGE. DO NOT PLACE THEM END-TO-END WITH THE POSITIVE (+) AND NEGATIVE (-) TERMINALS NEXT TO EACH OTHER (FIGURE 13).

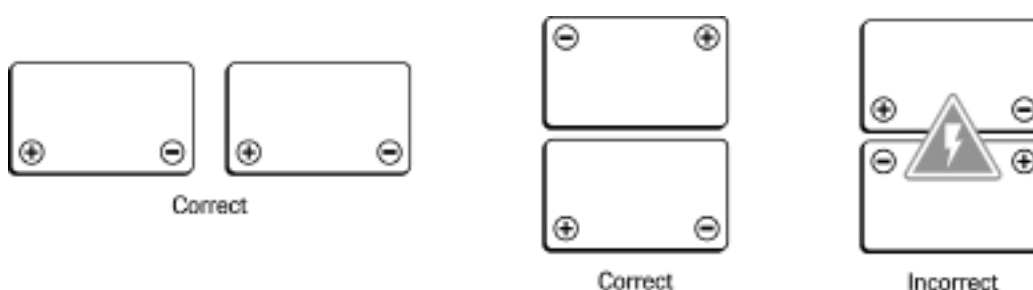

Figure 13

CLEANING INSTRUCTIONS

Tires

The tires should be cleaned with ordinary kitchen-type cleaners and a damp cloth. Don't use solvents on tires as they can cause tire material to break down or become too soft.

Cover

The cover can be easily cleaned. Apply water directly on a cloth, wring it out, and use the dampened cloth with mild soap to remove dirt and oils. Use same application to rinse off soap residue in order to eliminate any film build-up. You may also use this same procedure to clean under the cover by fully removing it (see Figure 14). DO NOT spray the vehicle with water. This can damage the electrical components. The cover may be waxed with car body wax and buffed by hand with a soft cloth.

Seat

The vinyl seat can be cleaned with a mild soap or detergent and a damp cloth. A vinyl cleaner can also be used. Cloth seats can be cleaned with a damp cloth or as any upholstery. Care should be taken not to soak cloth seats, as the interior foam can hold water.

Floor Mat

The floor mat should be cleaned with ordinary kitchen-type cleaners and a damp cloth. Do not use solvents on the floor mat, as they may cause the floor mat material to break down.



CAUTION

DO NOT EXPOSE THE AMIGO TO SPRAY-ON CLEANING SOLUTIONS AND EXCESSIVE MOISTURE SUCH AS SPRAYING IT WITH A GARDEN HOSE, SHOWER, OR LEAVING IT UNCOVERED IN RAIN. KEEP CLEANING SOLVENTS AWAY FROM ELECTRICAL WIRES AND CONNECTIONS.

MAINTENANCE

Minimum maintenance should prevent unnecessary repairs. You can get years of dependable operation if you follow the suggested maintenance schedule. Check the following:

Daily

Charge batteries daily when the Amigo is used. Charge the battery fully to ensure proper battery operation. Extended charging is good for the batteries and will not overcharge them.

Monthly

- Check and clean battery terminals and the wire connections as needed with a light piece of emery cloth or brush and mixture of $\frac{1}{2}$ cup baking soda to 1-1 $\frac{1}{2}$ cups water.
- Clean upholstery, plastic, and metal with a mild surface cleaner.
- Inspect batteries for any cracks or damage of any kind.
- Check and tighten any exposed fasteners.
- Make sure all fasteners are tight on all battery connections.
- Check tire pressure on pneumatic tires. When air filling tires, always refer to the manufacturer's specifications located on the face of the tire. Uneven tire pressure can cause excessive battery consumption and overheating of the controller, which can lead to failure of the vehicle.
- Check static ground wire located under vehicle. Replace if damaged or missing. Wire must be in contact with floor when operating the Amigo.
- If rubber boot on arm rest joint is missing, replace immediately.



WARNING

DO NOT EXCEED PROPER INFLATION LEVEL SPECIFIED ON TIRE OR TIRES MAY BE DAMAGED.

Six Months

- Check all screws and clips that are holding wheels for tightness and wear.
- Check all electrical connections for clean, tight contact.
- Charging connection should be inspected for tight connection.
- Check tires for wear.
- Inspect seat posts for wear.
- Clean and lubricate seat bearings on upper seat post.

Yearly

- Have your authorized service center check your Amigo completely.
- Grease axle and wheel hubs.
- Clean and lubricate steering column bearings.

Checking the General Condition

For maintenance operations, consult your authorized dealer who has all the necessary information. Once a year have the authorized dealer inspect your vehicle thoroughly and carry out in depth maintenance. Regular maintenance allows defective or worn parts to be identified and improves the normal operation of the vehicle and extends its working life.

Removing the Rear Cover

The Amigo RD and HD units have a hinged rear cover (Figure 14), which can be opened once the seat is removed. To open cover, tilt the handle fully forward to prevent scratching the rear cover on the handle screws. Remove rubber boot from lower seat post, pull cover off of the pins in the rear, lift the cover over the seat post and tilt cover forward. To close cover, reposition the handle to a comfortable position. Simply tilt cover rearward, guide cover over the seat post, and place cover on the pins in the rear. Ensure that the power cord is fully retracted after the cover is closed.

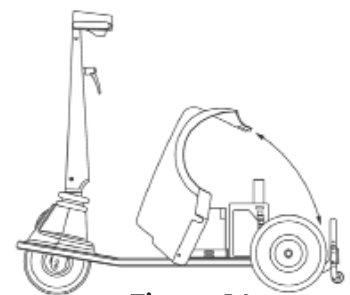

Figure 14

Lighting

The Amigo is equipped with a headlight and optional taillights. To replace the headlight, from the underside of the front housing where the headlight is located, gently pry the rubber seal from the housing and then install the new headlight assembly. To prevent the headlight assembly from spinning once it is mounted to the front housing, you may apply an adhesive such as hot melt glue. To replace the taillights, unscrew the nuts from the inside of the rear cover and install the new taillight assembly.

Battery Maintenance

Sealed deep-cycle batteries are used for operating your Amigo. They are maintenance-free and are transportable on aircraft, buses, trains, etc. as there is no danger of spillage. By following the charger and battery procedures, you can expect extended battery life.

Fasteners Replacement

Use only Grade 8 (U.S.) or 10.9 DIN (metric) in all applications (Figure 15). For service and replacement parts, we recommend Amigo authorized parts.

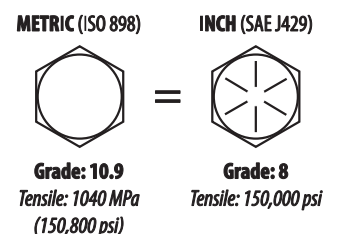

Figure 15

Transaxle Drive Systems

The transaxle drive is a precision assembly that is lubricated for long service. Do not attempt to open or service the assembly, this will void the warranty.

Microprocessor Controller

Do not attempt to service the controller or related electronic components, as this will void the warranty.

Circuit Breaker Replacement Instructions

An automatic resetting circuit breaker (Figure 16) protects the wiring and batteries in the event of a short circuit. If the cart stops, check for overloads or short circuits before continuing to operate. The circuit breaker is located under the rear cover and attached to the positive terminal on the batteries. Tampering with electrical or mechanical parts will invalidate your warranty.

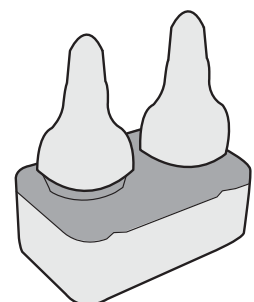

Figure 16
(Circuit Breaker)



WARNING

DO NOT CONTINUE TO OPERATE THE AMIGO UNTIL THE CIRCUIT BREAKER IS REPAIRED.

TROUBLESHOOTING

Serial Number Location

For operation or service questions, you can call the Amigo service hotline at 800-248-9131 or 989-777-0910 from 8 a.m. to 5:30 p.m. Monday through Friday, email service@myamigo.com, or visit myamigo.com/service to fill out a request form online. Please reference your serial number when calling.

There are two serial number locations on each Amigo. One serial number is located below the handle on the steering column (Figure 17). The other serial number is located under the rear cover next to the right wheel from behind the Amigo (Figure 18).

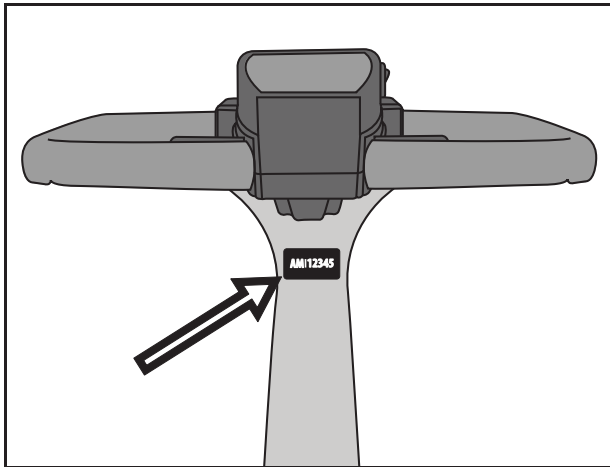

FIGURE 17

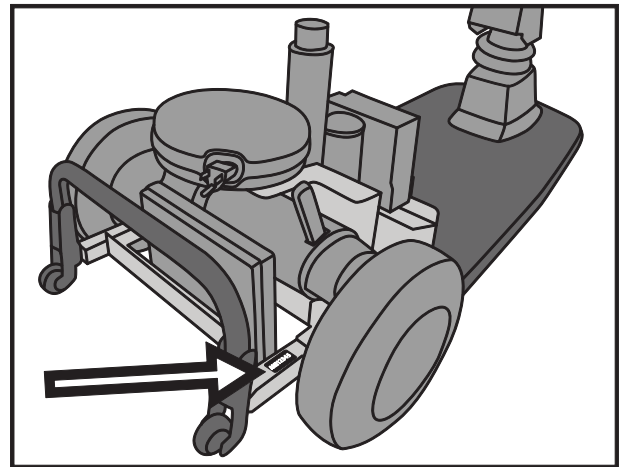

FIGURE 18

Battery Indicator LED

The controller has a built-in diagnostic feature that will cause the diagnostic indicator LEDs to flash a numeric code to indicate when there is a service problem. Please refer to page 14 for detailed information on service codes. Under normal operating conditions, the battery indicator LED will flash to indicate three different situations. Battery indicator LED locations are shown below on the Hi/Lo handle (Figure 19) and the TouchTron handle (Figure 20).

- To indicate a low battery condition when driving.
- To indicate the battery charging cycle has started.
- To indicate when the batteries are fully charged during the charging cycle.

Battery indicator LED

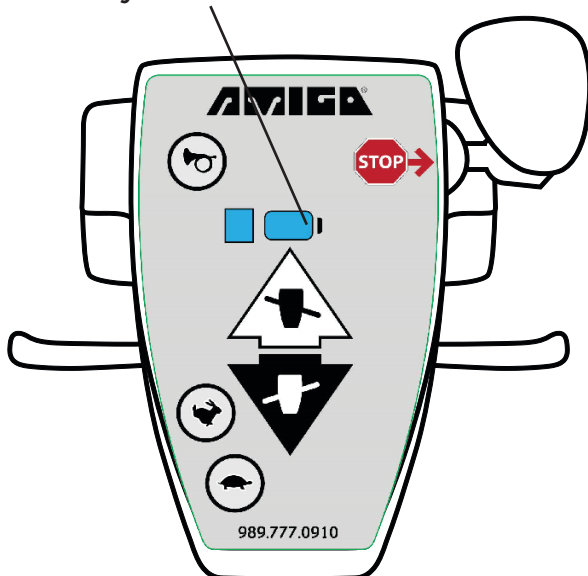

Figure 19

Battery indicator LED

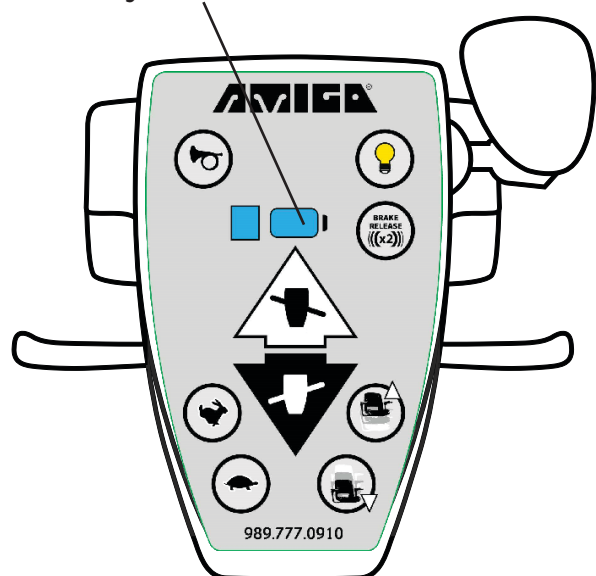

Figure 20

Diagnostic Codes

The Amigo controller has a built-in diagnostic feature that will cause the diagnostic LED lights (Figure 21) to flash a numeric code, indicating service issues to aid in diagnosis. When indicating a service problem, the diagnostic lights will flash, hesitate for a moment, and then flash again. Follow the code listings below to determine the problem. Solutions should be attempted in the order they are written. If the code indicates a service problem, contact your local service representative or call the Amigo service department at 800-248-9131 or 989-777-0910 for instructions to verify and correct the problem.

Diagnostic light location

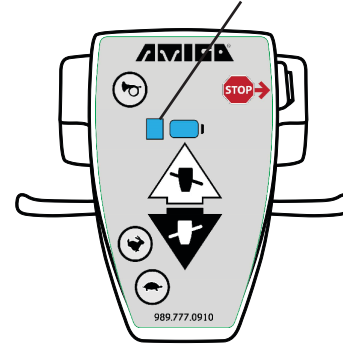

Figure 21

LED CODE	CAUSE	SOLUTIONS
1	EM Brake windings or connections are shorted	<ol style="list-style-type: none"> (1) Unplug handle cable and plug back in. (2) Check all wiring connections and output. (3) Disconnect brake and cycle key, if code changes to 2, replace brake. (4) Replace controller
2	EM Brake windings or connections are open or EM brake release lever in "freewheeling position"	<ol style="list-style-type: none"> (1) Ensure EM brake lever is in normal/drive position (2) Unplug handle cable and plug back in. (3) Check all wiring connections and output. (4) Replace brake. (5) Replace controller.
3	Motor windings or connections are shorted	<ol style="list-style-type: none"> (1) Check motor wiring connections. (2) Disconnect brake and cycle key, if code changes to 2, replace motor. (3) Replace controller.
4	Motor windings or connections are open	<ol style="list-style-type: none"> (1) Ensure brake lever is in normal/drive position. (2) Check motor wiring connections. (3) Replace motor. (4) Replace controller.
5	Throttle hall effect or throttle circuitry reading fail band fault	<ol style="list-style-type: none"> (1) Check to ensure handle cable is in good condition. (2) Check that throttle lever moves freely and returns to center. (3) Replace throttle hall effect.
6	Over temperature condition	<ol style="list-style-type: none"> (1) Allow to sit idle for 15 minutes, restart and see if code disappears. (2) Ensure EM brake and / or motor is not causing excessive amperage draw. (3) Replace controller
7	Charger not dropping back into "float mode" during battery charge cycle	<ol style="list-style-type: none"> (1) Replace charger wiring. (2) Replace battery charger. (3) Replace controller
8	Power shortage	<ol style="list-style-type: none"> (1) Check / Replace batteries. (2) Check / Replace controller
8	Controller drive FETS shorted	<ol style="list-style-type: none"> (1) Replace controller
8	Controller regenerative braking FETS shorted	<ol style="list-style-type: none"> (1) Replace controller.

ELECTROMAGNETIC INTERFERENCE



WARNING

RADIO WAVE SOURCES MAY AFFECT POWERED MOBILE VEHICLE CONTROL.

Electromagnetic Interference (EMI) From Radio Wave Sources

Power-operated vehicles (POV) may be susceptible to electromagnetic interference (EMI), which is interfering electromagnetic energy (EM) emitted from sources such as radio stations, TV stations, amateur radio (HAM) transmitters, two-way radios, and cellular phones. The interference (from radio wave sources) can cause the POV to release its brakes, move by itself, or move in unintended directions. It can also permanently damage the POV's control system.

Three Main Sources of Radiated EMI

There are a number of sources of relatively intense electromagnetic fields in the everyday environment. Some of these sources are obvious and easy to avoid. Others are not apparent and exposure is unavoidable. The following are the three broad classifications of EMI sources:

- Handheld portable transceivers (transmitters-receivers) with antenna mounted directly on the transmitting unit. Examples include: citizens band (CB) radios, "walkie talkie," security, fire and police transceivers, cellular telephones, and other personal communication devices. Some of these devices transmit signals while they are on, even when they are not being used.
- Medium-range mobile transceivers, such as those used in police cars, fire trucks, ambulances, and taxis. These devices usually have the antenna mounted on the outside of the vehicle.
- Long-range transmitters and transceivers, such as commercial broadcast transmitters (radio and TV broadcast antenna towers) and amateur (HAM) radios.

POV EMI Warnings

Because electromagnetic energy rapidly becomes more intense as one moves closer to the source, the electromagnetic fields from handheld radio wave sources (transceivers) are of special concern. It is possible to unintentionally bring high levels of electromagnetic energy very close to the POV's control system while using these devices. This can affect POV movement and braking. The warnings listed below are recommended to prevent possible interference with the control system of the POV, which could result in serious injury.

- DO NOT operate or turn on handheld personal communication devices, such as Citizens Band (CB) radios and cellular phones while the vehicle is turned on.
- Avoid using your POV near transmitters such as radio stations, TV stations, and alarm systems.
- If unintended movement or brake release occurs, turn the vehicle off as soon as it is safe.
- Be aware that adding accessories or components or modifying the vehicle may make it more susceptible to interference from radio wave sources. There is no easy way to evaluate their effect on the overall immunity of the vehicle.
- Report all incidents of unintended movement or brake release to the mobile vehicle manufacturer and note whether there is a source of EMI nearby.

EMI Immunity

The intensity of the interfering EM energy can be measured in volts per meter (V/M). Each POV can resist EMI up to a certain intensity. This is called its "immunity level." The higher the immunity level, the greater the protection.

- 20 volts per meter (V/M) is a generally achievable and useful immunity level against EMI (as of May 1994). The higher the level, the greater the protection.
- The immunity level of this product is not known.

Wiring Diagram

RT | Hi/Lo

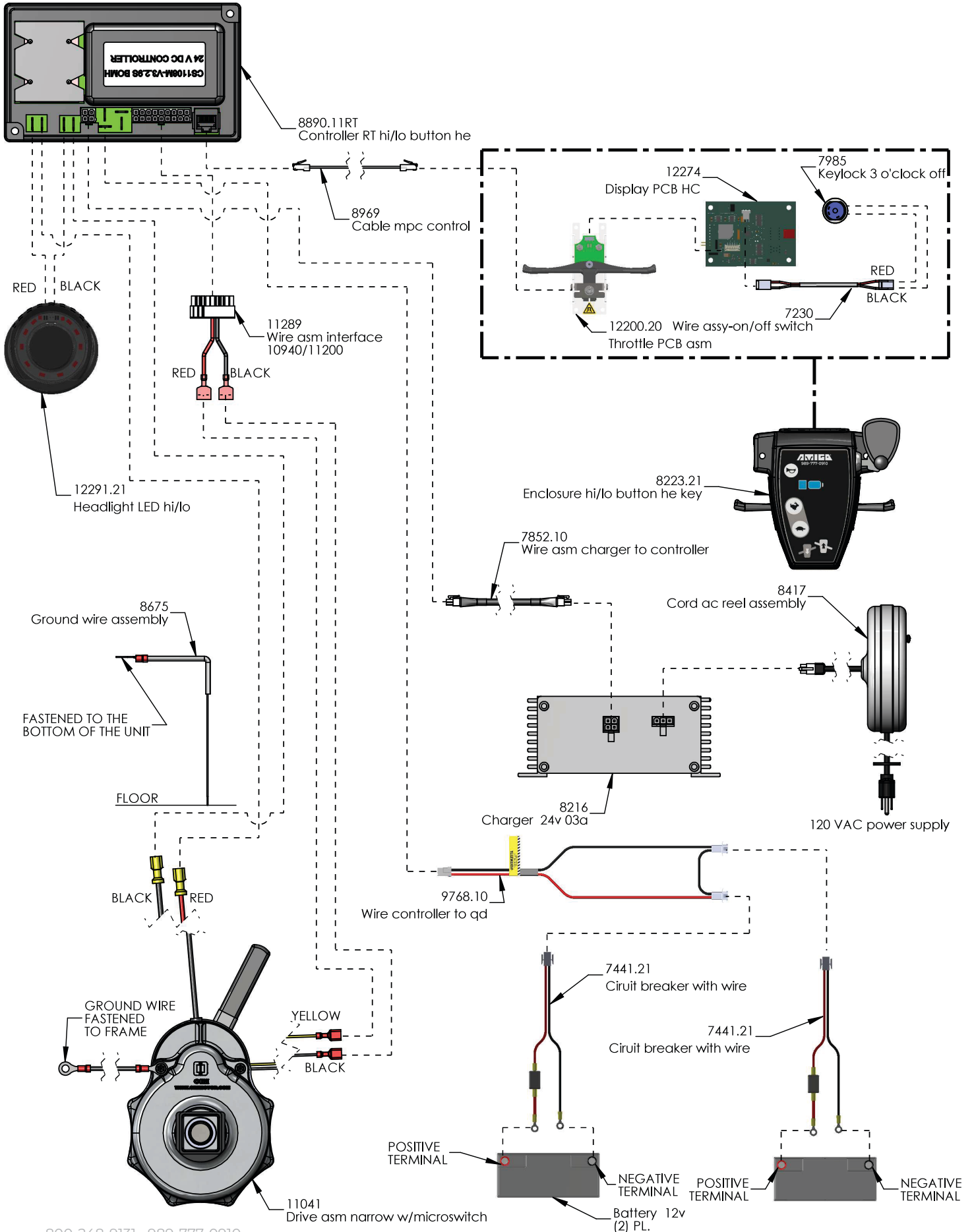

Wiring Diagram

RT | TouchTron

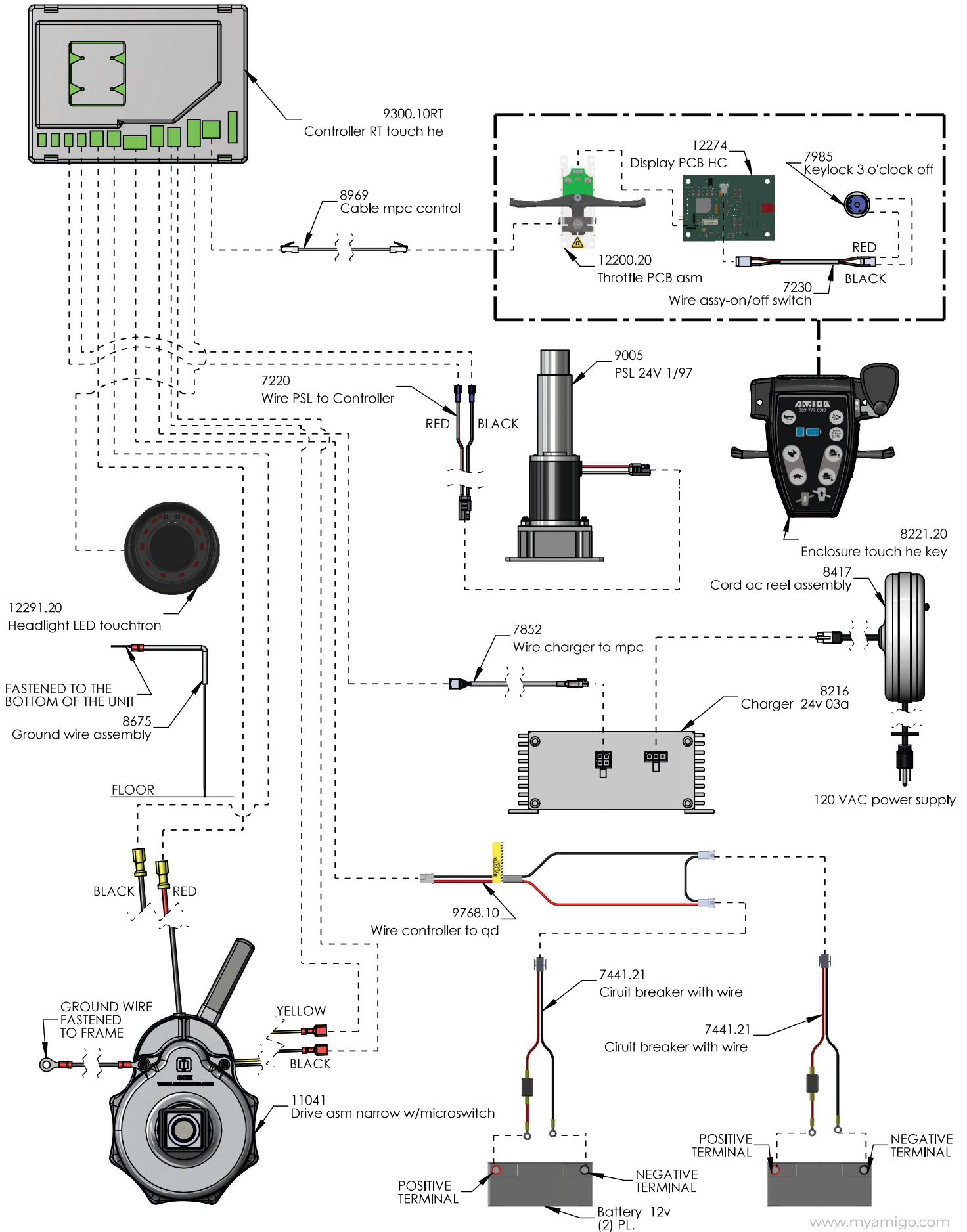

Wiring Diagram

RD | Hi/Lo

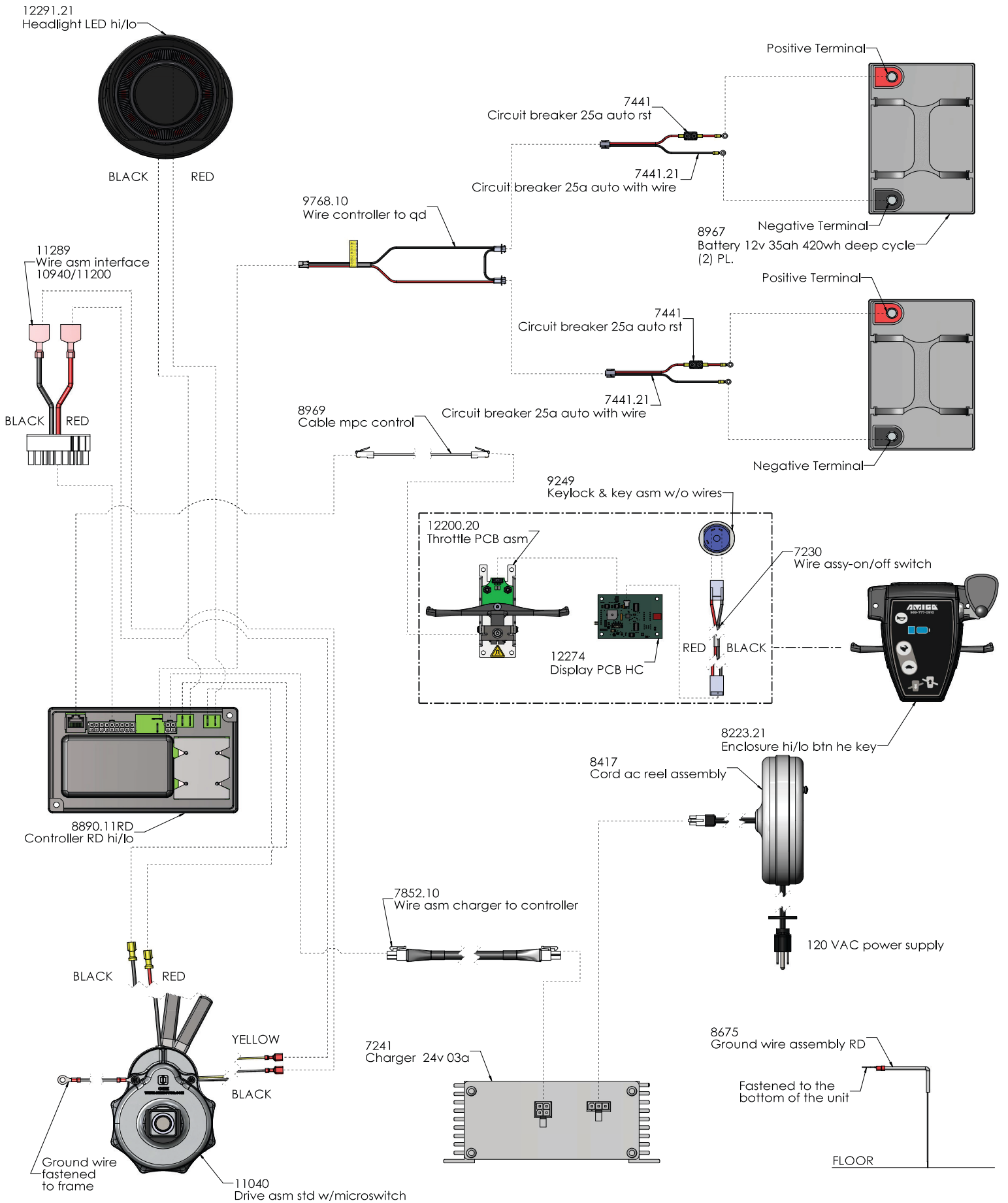

Wiring Diagram

RD | TouchTron

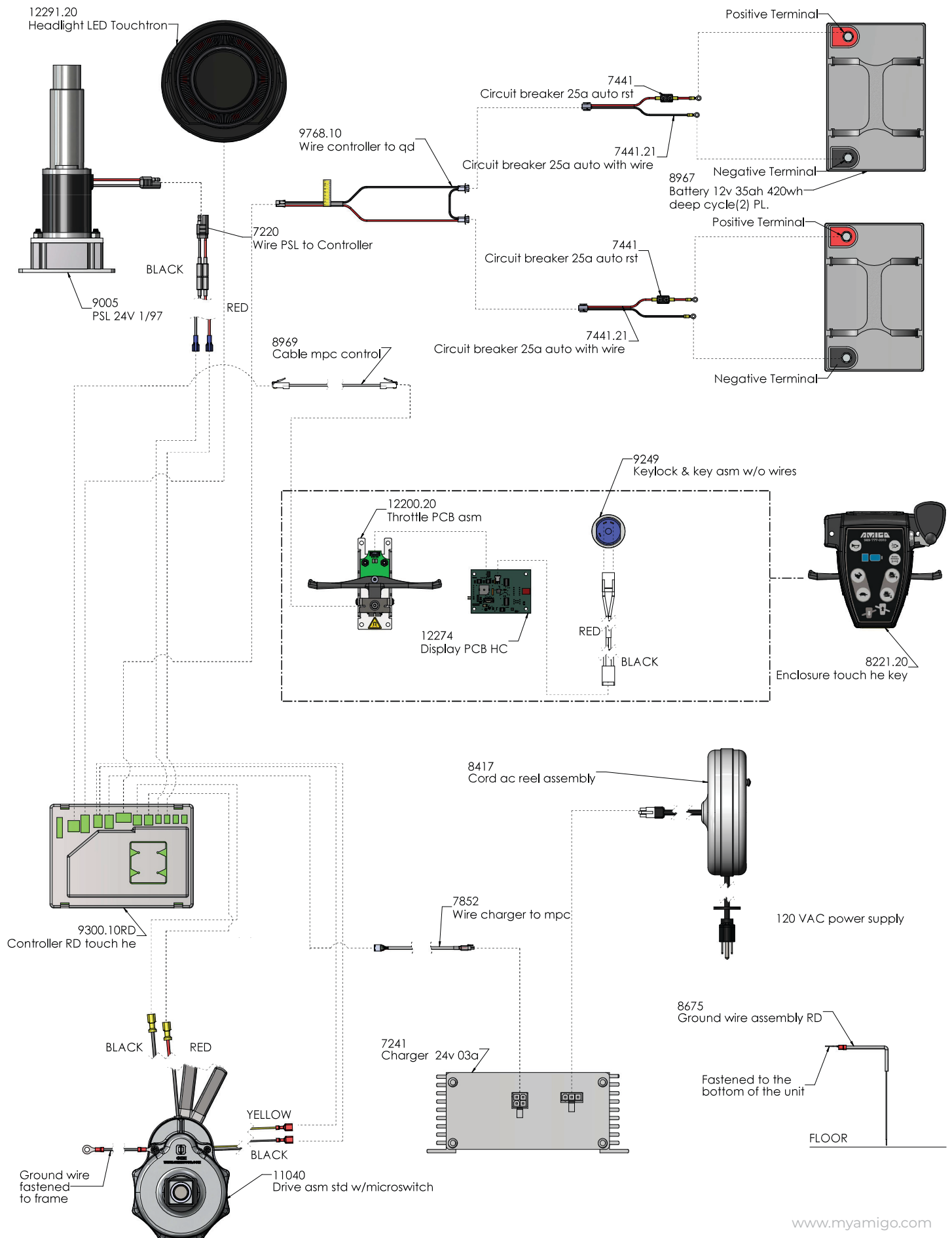

Wiring Diagram

HD | Hi/Lo

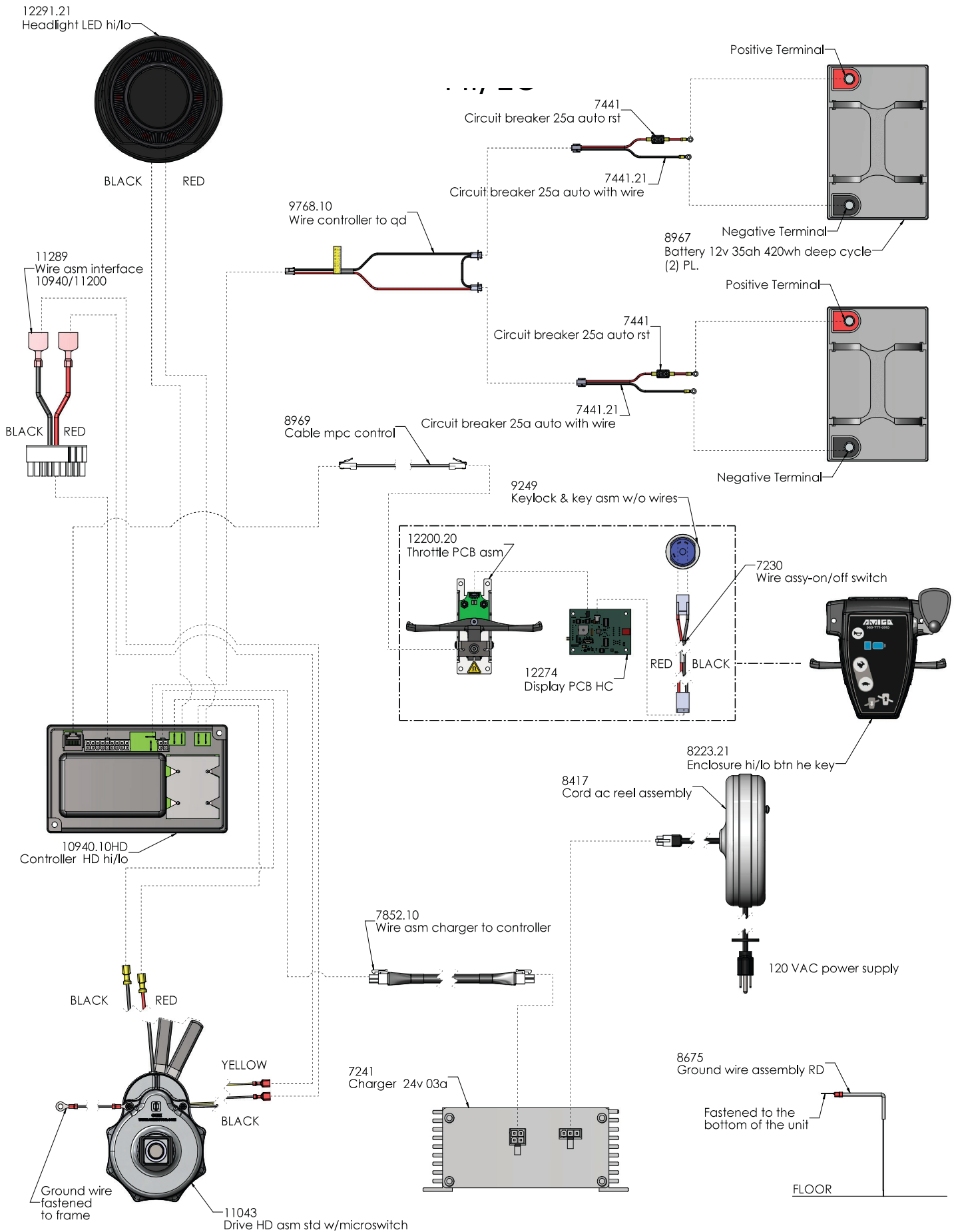

EXPLODED VIEW

RT

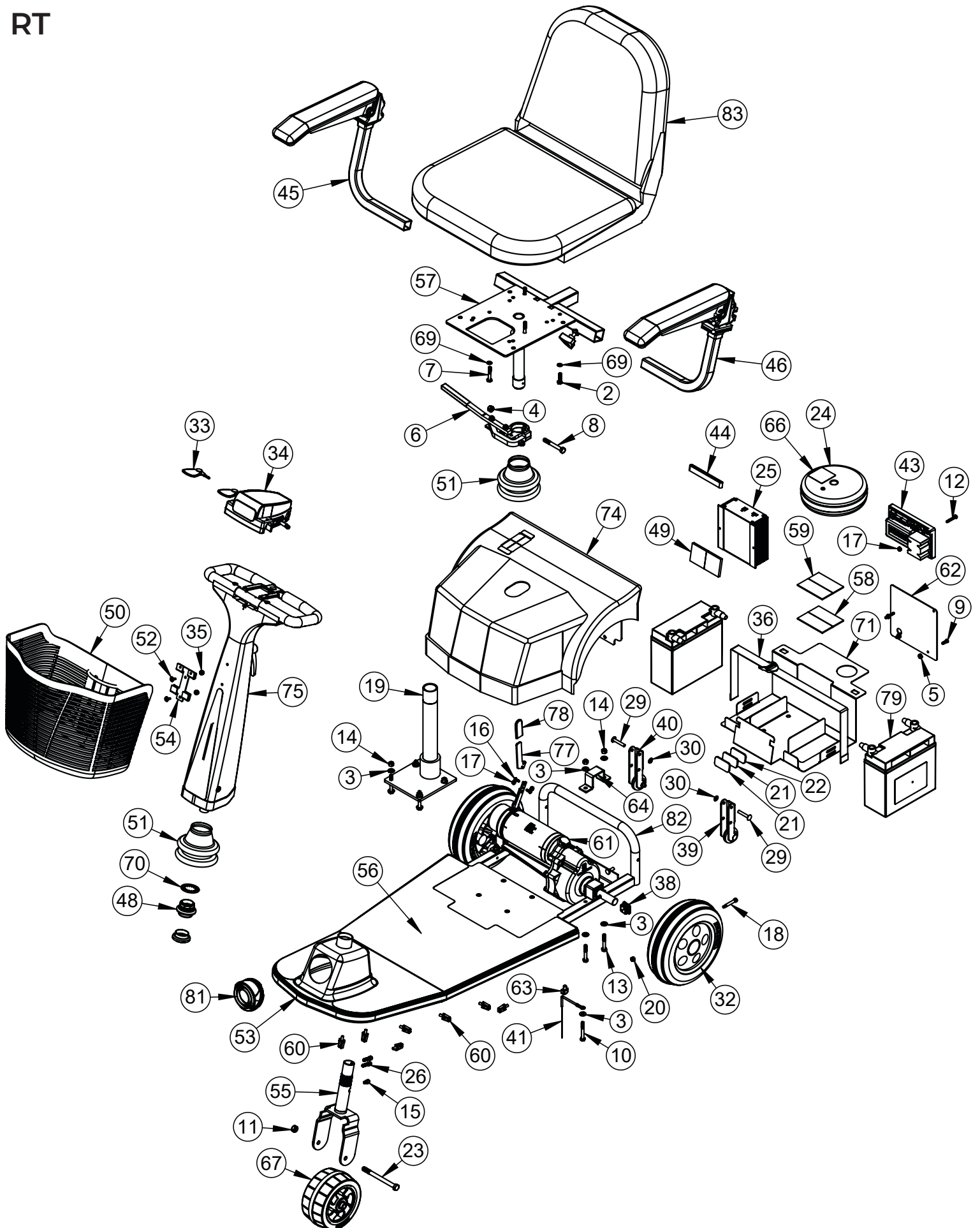

PARTS LIST | RT

Item No.	Part No.	Description	QTY.
1	0106	Ty-rap 7.5" black	1
2	1180	Screw 1/4-20 x 1.00 hx hd	2
3	1192	Washer .281id .63od .06 flat	16
4	1253	Nut 5/16-18 hex keps	1
5	1264	Nut #10-32 Keps	2
6	1299	Seat lock right	1
7	1344	Screw 1/4-20 x 1.50 hx hd	2
8	1450	Screw 5/16-18 X 2.50 hx hd gr8	1
9	1479	Screw #10-32 X .625 rd hd	2
10	1621	Screw 1/4-20 X 2.0 hex hd	4
11	2237	Nut 3/8-24 hex	1
12	2433	Screw #8-32 X 1.25 flange hex	2
13	2822	Screw 1/4-20 X 1.75 hex hd gr8	4
14	3622	Nut 1/4-20 hex nylon	8
15	5190	Screw 1/4-28 X .375 shcs hd	1
16	5510	Screw #8-32 X .50 rd hd phill	2
17	5630	Nut #8-32 hex keps	4
18	5865	Screw #10-24 X .25 x 1.25 shld	2
19	6191	Seat post lower weldment	1
20	6227	Nut #10-24 hex nylon	2
21	6304	Velcro dual lock 400/IN 2"pc	2
22	6305	Velcro dual lock 170/IN 2"pc	1
23	6505	Screw 3/8-24 X 4.5 lg hx hd gr8	1
24	7121.10	Reel enclosure w/stop washer	1
25	7241	Charger standard 24v	1
26	7281	Screw 1/4-20 X .88 shcs	2
27	7441	Circuit breaker 25a auto reset	1
29	7599	Rivet truss head .25"D X 1.5"L	2
30	7600	Nut 1/4 stud push	2
31	7852.10	Wire charger to controller	1
32	7912.12	Wheel 09" rer TL chr hub	2
33	7997	Key extension (key with fob)	1
34	8223.21	Enclosure hi/lo button he key	1
35	8262	Nut #10-32 hex nylon insert	2
36	8300	Strap battery retaining	1
37	8354	Warning tag fda emi rfi	1
38	8534	Plug tube square	2
39	8670.20	Wheel 01.6" stab HC brkt lt	1
40	8670.21	Wheel 01.6" stab HC brkt rt	1
41	8675	Ground wire assembly RD	1

Item No.	Part No.	Description	QTY.
42	8680	Label battery power cell+	2
43	8890.11RT	Controller RT hi/lo button he	1
44	8944	Band mounting cpu & chgr	1
45	9247	Arm rt remove	1
46	9248	Arm lt remove	1
47	9768.10	Wire controller QD commercial	1
48	10050	Bearing headset 1-1/8"	1
49	10151	Foam insert adhesive backed	1
50	10289.20	Basket HC	1
51	10516	Handle boot lower pvc free	2
52	10547	Screw #10-32 x .50 truss	2
53	10568	Bumper trim 71" RT	1
54	10571	Basket brkt HC	1
55	10709	Fork weldment rt platform	1
56	10710	Mat RT	1
57	10765.20	Seat post upper std acc ad	1
58	10970-RAW	Tape velcro loop 1.5 wide	2
59	10971-RAW	Tape velcro hook 1.5 wide	2
60	10976	Clip wire guide	7
61	11041	Drive rear RT	1
62	11082	Plate controller mounting	1
63	11125	Clip wire guide .35 ID	1
64	11174	Clamp drive	2
65	11187	Label serial number AMI	1
66	11192	Label cord reel disassembly	1
67	11276.22	Wheel 06" 2.5 wd frt blk tire	1
68	11289	Wire asm interface 10940/11200	1
69	11311	Washer lock heavy split 1/4"	4
70	11459	Washer 1.125id x 1.83od lock	1
71	11556	Pan rear RT platform	1
72	11839	Boot battery .64 dia red	2
73	11861	Cable tie 8"	1
74	11872.20	Cover RT maroon w/labels	1
75	11881.20	Handle w/o enclosure maroon	1
76	12095	Boot battery .64 dia black	2
77	12109	RT brake lever ext	1
78	12117	Boot brake lever RT	1
79	12128	Battery 12v 20ah	2
80	12280	Label prop65 eng	1
81	12291.21	Headlight LED hi/lo	1
82	13289	Platform RT maroon	1
83	300369	Seat 18" prem l blk	1

EXPLODED VIEW

RD

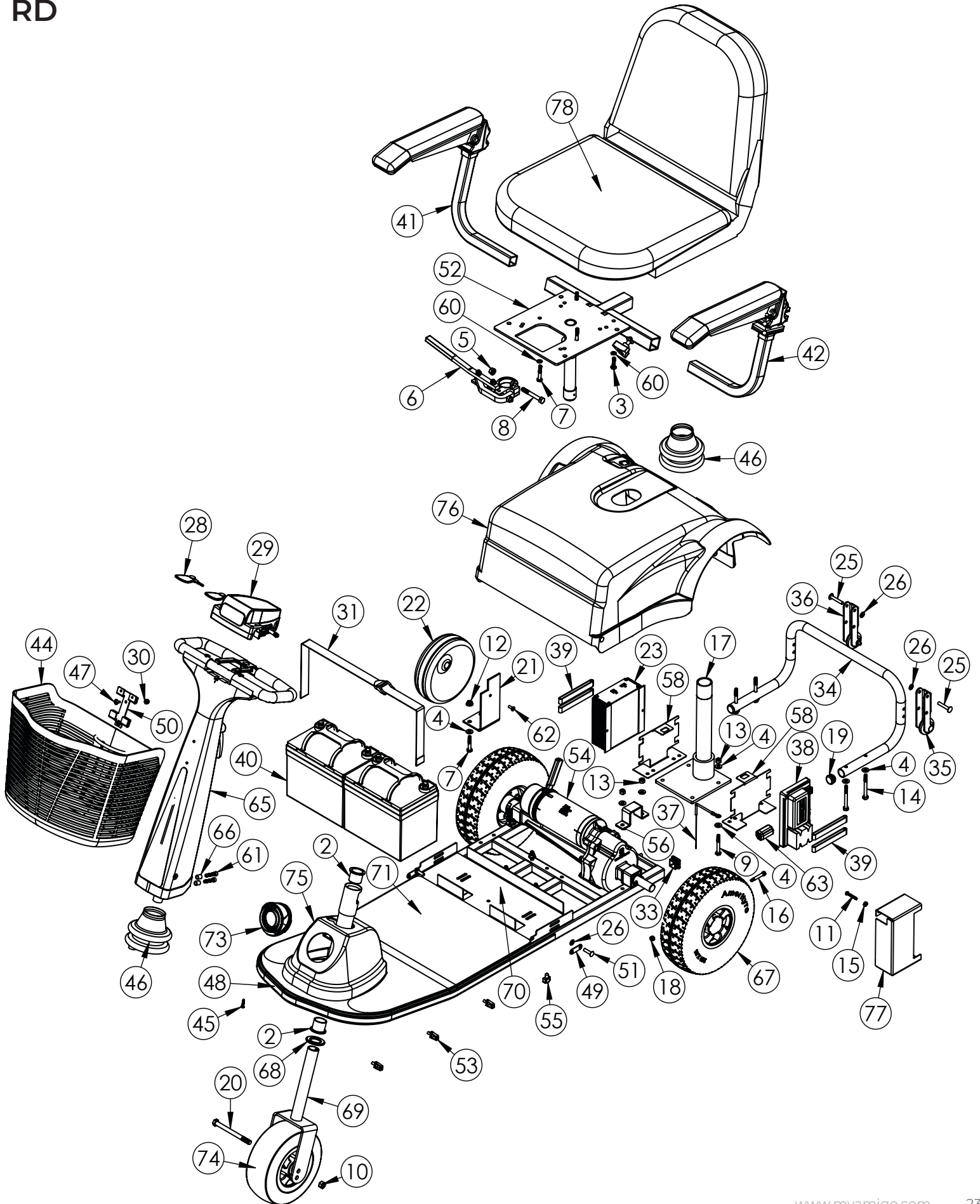

PARTS LIST | RD

Item No.	Part No.	Description	QTY.
1	0106	Ty-rap 7.5" black	2
2	1025	Bearing 1.182od 1.067id 1.06lg	2
3	1180	Screw 1/4-20 x 1.00 hx hd	2
4	1192	Washer .281id .63od .06 flat	18
5	1253	Nut 5/16-18 hex keps	1
6	1299	Seat lock right	1
7	1344	Screw 1/4-20 x 1.50 hx hd	4
8	1450	Screw 5/16-18 x 2.50 hx hd gr8	1
9	1621	Screw 1/4-20 x 2.0 hex hd	4
10	2237	Nut 3/8-24 hex	1
11	2433	Screw #8-32 x 1.25 flange hex	2
12	3083	Nut 1/4-20 serrated flanged	2
13	3622	Nut 1/4-20 hex nylon	8
14	4953	Screw 1/4-20 x 2.50 hex hd gr8	4
15	5630	Nut #8-32 hex keps	2
16	5865	Screw #10-24 x .25 x 1.25 shld	2
17	6191	Seat post lower weldment	1
18	6227	Nut #10-24 hex nylon	2
19	6463	Plug tube round	2
20	6505	Screw 3/8-24 x 4.5 lg hx hd gr8	1
21	6993	Cord reel brkt	1
22	7121.10	Reel enclosure w/stop washer	1
23	7241	Charger standard 24v	1
24	7441	Circuit breaker 25a auto reset	2
25	7599	Rivet truss head .25"D x 1.5"L	2
26	7600	Nut 1/4 stud push	4
27	7852.10	Wire charger to controller	1
28	7997	Key extension (key with fob)	1
29	8223.21	Enclosure hi/lo button he key	1
30	8262	Nut #10-32 hex nylon insert	2
31	8300	Strap battery retaining	1
32	8354	Warning tag fda emi rfi	1
33	8534	Plug tube square	2
34	8669	Bumper rear tube blk	1
35	8670.20	Wheel 01.6" stab HC brkt lt	1
36	8670.21	Wheel 01.6" stab HC brkt rt	1
37	8675	Ground wire assembly RD	1
38	8890.11RD	Controller RD hi/lo button he	1
39	8944	Band mounting cpu & chgr	4

Item No.	Part No.	Description	QTY.
40	8967	Battery 12v 35ah 420wh deep cycle	2
41	9247	Arm rt remove	1
42	9248	Arm lt remove	1
43	9768.10	Wire controller to QD commercial	1
44	10289.20	Basket HC	1
45	10346	Screw #8 x .75 type b phillips	4
46	10516	Handle boot lower pvc free	2
47	10547	Screw #10-32 x .50 truss	2
48	10567	Bumper trim 67" RD	1
49	10569	Link hinge	2
50	10571	Basket brkt HC	1
51	10574	Rivet solid steel 1/4" x 1.00	2
52	10765.20	Seat post upper std acc ad	1
53	10976	Clip wire guide	3
54	11040	Drive rear RD	1
55	11125	Clip wire guide .35 ID	1
56	11174	Clamp drive	2
57	11187	Label serial number AMI	1
58	11264	Bracket electrical mount 10509	2
59	11289	Wire asm interface 10940/11200	1
60	11311	Washer lock heavy split 1/4"	4
61	11335	Screw 1/4-20 x 1.25 shcs	2
62	11377	Screw #10-24 x .50	1
63	11642	Filter ferrite bead	1
64	11861	Cable tie 8"	3
65	11881.20	Handle w/o enclosure maroon	1
66	12009	Spacer .259id .375od .49	2
67	12172	Wheel 10.5" rer urethane blk	2
68	12239	Bearing thrust 1.81OD 1.09ID	1
69	12261.10	Fork SS/RD	1
70	12262.11	Platform SS/RD blk	1
71	12279.10	Mat SS/RD	1
72	12280	Label prop65 eng	1
73	12291.21	Headlight LED hi/lo	1
74	12462	Wheel 8" front HC black	1
75	13290	Cover front RD maroon	1
76	13291.20	Cover RD maroon w/labels	1
77	13330	Guard 1108M/S4 controller	1
78	300369	Seat 18" prem l blk	1

PARTS LIST | HD

Item No.	Part No.	Description	QTY.
1	1025	Bearing 1.182od 1.067id 1.06lg	2
2	1192	Washer .281id .63od .06 flat	18
3	1253	Nut 5/16-18 hex keps	5
4	1257	Screw 5/16-18 x 1.00 hex hd	4
5	1344	Screw 1/4-20 X 1.50 hx hd	2
6	1450	Screw 5/16-18 X 2.50 hx hd gr8	1
7	1621	Screw 1/4-20 X 2.0 hex hd	4
8	2237	Nut 3/8-24 hex	1
9	2433	Screw #8-32 x 1.25 flange hex	2
10	3083	Nut 1/4-20 serrated flanged	2
11	3622	Nut 1/4-20 hex nylon	8
12	4953	Screw 1/4-20 X 2.50 hex hd gr8	4
13	5630	Nut #8-32 hex keps	2
14	6191	Seat post lower weldment	1
15	6463	Plug tube round	2
16	6505	Screw 3/8-24 x 4.5 lg hx hd gr8	1
17	6993	Cord reel brkt	1
18	7121.10	Reel enclosure w/stop washer	1
19	7241	Charger standard 24v	1
20	7441	Circuit breaker 25a auto reset	2
21	7599	Rivet truss head .25"D x 1.5"L	2
22	7600	Nut 1/4 stud push	4
23	7852.10	Wire charger to controller	1
24	7997	Key extension (key with fob)	1
25	8223.21	Enclosure hi/lo button he key	1
26	8262	Nut #10-32 hex nylon insert	2
27	8300	Strap battery retaining	1
28	8354	Warning tag fda emi rfi	1
29	8534	Plug tube square	2
30	8669	Bumper rear tube blk	1
31	8670.20	Wheel 01.6" stab HC brkt lt	1
32	8670.21	Wheel 01.6" stab HC brkt rt	1
33	8675	Ground wire assembly RD	1
34	8944	Band mounting cpu & chgr	4
35	8967	Battery 12v 35ah 420wh deep cycle	2
36	9250	Arm rt remove 2" high	1
37	9251	Arm lt remove 2" high	1
38	9768.10	Wire controller to QD commercial	1

Item No.	Part No.	Description	QTY.
39	9983.30	Seat lock 20/22" rt	1
40	10289.20	Basket HC	1
41	10346	Screw #8 x .75 type b phillips	4
42	10516	Handle boot lower pvc free	2
43	10547	Screw #10-32 x .50 truss	2
44	10567	Bumper trim 67" RD	1
45	10569	Link hinge	2
46	10571	Basket brkt HC	1
47	10574	Rivet solid steel 1/4" x 1.00	2
48	10585	Cap hub mag style blk	2
49	10940.11HD	Controller HD hi/lo button he	1
50	10976	Clip wire guide	3
51	11043	Drive rear HD	1
52	11081.20	Seat post upper hd acc ad	1
53	11125	Clip wire guide .35 ID	1
54	11174	Clamp drive	2
55	11187	Label serial number AMI	1
56	11264	Bracket electrical mount 10509	2
57	11289	Wire asm interface 10940/11200	1
58	11312	Washer 5/16 split lock heav	4
59	11335	Screw 1/4-20 x 1.25 shcs	2
60	11377	Screw #10-24 x .50	1
61	11642	Filter ferrite bead	1
62	11861	Cable tie 8"	3
63	11881.20	Handle w/o enclosure maroon	1
64	12009	Spacer .259id .375od .49	2
65	12181	Wheel 10" urethane HD key blk	2
66	12239	Bearing thrust 1.81OD 1.09ID	1
67	12261.10	Fork SS/RD	1
68	12262.11	Platform SS/RD blk	1
69	12279.10	Mat SS/RD	1
70	12280	Label prop65 eng	1
71	12291.21	Headlight LED hi/lo	1
72	12376.20	Seat 20" HC	1
73	12462	Wheel 8" front HC black	1
74	13290	Cover front RD maroon	1
75	13291.25	Cover HD maroon w/labels	1
76	13330	Guard 1108M/S4 controller	1

AMIGO MOBILITY HEALTHCARE WARRANTY

General Warranty Provisions

Amigo Mobility International, Inc. (AMI) warrants the original, completed Amigo it manufactures only to the original owner. If warranty card or proof of purchase is not received, warranty begins on the date the Amigo was shipped. This warranty supersedes and is in lieu of all other warranties, expressed or implied, and no person, agent or dealer is authorized to give any warranties on behalf of AMI, nor to assume for AMI any other liability concerning any of its products unless made in writing and signed by an official of AMI. This warranty gives you specific rights, with the possibility of other rights, which vary depending upon your locality. The warranties on this page do not cover the failure of any part or accessory due to:

- Shipping damage.
- Abuse, misuse, accidental damage, or acts of nature.
- Exceeding the specified weight capacity of the model.
- Improper installation or opening sealed components.
- Modifying the Amigo or installing accessories not authorized by AMI.

Warranty Coverage

AMI will repair or replace a part that is defective in material or workmanship under normal use. AMI may use factory-recertified parts (rather than new parts) for some warranty repairs. Warranty replacement parts are covered for the remainder of the Amigo unit warranty. AMI covers labor warranty at factory headquarters in Bridgeport, Michigan for the first 60 days of ownership. Freight charges are not included under labor warranty.

- Structural components – platform, frame and lower seat post (non PSL) have a limited lifetime warranty (7 years).
- Main components – controller, charger, motor, powered seat lift (PSL), and transaxle have a two-year warranty.
- Seats and other components have a one-year warranty (cuts and tears in seats are not covered by warranty).
- Batteries supplied by AMI are warranted for one year (freight not included after six months) and carry Amigo brand labels. **Damage caused by battery moisture, spillage, or leakage is exclusive of warranty.** Lithium-ion batteries carry the following warranty:
 - Warranty period is 60 months beginning when the Amigo healthcare model or batteries are shipped from AMI factory.
 - Serial number of unit/date code on battery will be required.
 - Warranty covers defects in workmanship and material.
 - Failure constitutes a fully recharged battery with less than 50% of its rated capacity under normal operating charging conditions and is covered within the 60 month period.
 - Lithium-ion batteries must be returned to AMI. Upon receipt, batteries will be tested to confirm warranty conditions are met.
 - First 36 months' replacement batteries will be lithium-ion; 37 months and older may receive sealed lead-acid batteries.
- AMI is obligated to repair or replace products/parts returned by the purchaser and found to be defective under warranty at our factory in Bridgeport, Michigan.
- If inspection determines that a returned part or unit is fully functional or inoperable due to a non-warranty nature, it will be returned at expense of the owner.
- Parts purchased separately from the original unit, or rebuilt units, carry a one year warranty against defects in material and workmanship.

Customer Satisfaction

Complete satisfaction with your Amigo is our main goal. If you are not satisfied with any maintenance or repair work completed by a local Amigo dealership, please follow these two steps:

1. Review your concerns with the dealership's management (service manager or general manager). In most cases, a satisfactory solution is found.
2. Occasionally, an Amigo owner will not be fully satisfied with a dealer's decision or actions. In that case, contact Amigo customer service at 800-248-9131. Having the following information available will expedite response time:
 - Serial number of your Amigo (see page 13 for location of serial number).
 - Name, city, and state of the dealer who sold you the Amigo.
 - Date and reason for each visit to dealership.



Improving Lives Through Mobility® since 1968

AMIGO MOBILITY INTERNATIONAL, INC.
6693 Dixie Highway, Bridgeport, MI 48722-9725
Phone 800-248-9131 or 989-777-0910
Fax 800-334-7274 • www.myamigo.com