AMIGC RWD

PERSONAL MOBILITY AID



TABLE OF CONTENTS

| | <u>Page</u> |
|--|----------------|
| FEATURES | 1 |
| SAFETY TIPS AND HELPFUL HINTS | 1 |
| ASSEMBLY INSTRUCTIONS | 2 |
| Handle | 2 |
| Seat Assembly | 2 |
| Seat Height Adjustment | 2 |
| Seat positioning Adjustment | 2 |
| Installation & Removal of Wide-Track Duals | 3 |
| OPERATING THE UNIT | 4 |
| SPEED LIMIT ADJUSTMENT | 4 |
| DRIVING THE UNIT | 5 |
| Turning | 5 |
| Brake Lock | 6 |
| Manual Pushing | 6 |
| AmigoLift Powerseat | 6 |
| POWER CELL INFORMATION & CHARGING INSTRUCTIONS | 7 |
| General Information | 7 |
| Preparing to Charge | 7 |
| Charger Location | 7 |
| DC Connection Precautions | 7 |
| Charging Instructions | 7 |
| Charging Guidelines | 8 |
| Disconnecting the Charger | 7/8 |
| POWER CELL STATUS/POWER ON INDICATOR LIGHT | 8 |
| CIRCUIT BREAKER | 9 |
| TRANSPORTING YOUR RWD UNIT | 9 |
| By Car | 8/9 |
| By Airplane | 9 |
| Ground | 9 |
| MAINTENANCE INFORMATION | 10 |
| SERVICE INFORMATION | 10 |
| AmigoLift Power Seat Care | 10/11 |
| Bearing Inspection | 11 |
| Differential | 11 |
| Controller | 11 |
| REPLACING MOTOR DRIVE BELT | 12 |
| REPLACING REAR DRIVE WHEEL TIRE OR INNER TUBE | 13 |
| REPLACING TIRE OR INNER TUBE ON WIDE-TRACK DUALS | 14 |
| ADJUSTING BELT TENSION AND CHECKING PULLEY ALIGNMENT | 14/15 |
| AMIGO RWD ILLUSTRATION | 16 |
| AMIGO RWD PARTS LIST | 17/18/19 |
| WIRING DIAGRAMS | 20/21 |
| WARRANTY | ON Back Cover. |

FEATURES

- Easily removable 24 ampere-hour maintenance free power cells
- Adjustable seat height
- 360 degree swivel seat, lockable in any position
- Rear wheel drive
- Dynamic & regenerative braking
- AmigoTech Electronic System
- Silent, variable speed, solid state controller
- 24 volt, permanent magnet, heavy-duty DC motor with built-in gear box.
- Power cell status LED light, located on front wheel cover.
- Power On/Off switch, operated by thumb control lever on handle.
- High strength aluminum platform
- High impact ABS covers
- Rear wheel parking brake
- Heavy-duty, rugged differential
- Molded rubber, protective bumper
- Sturdy, removable handle
- Rear bumper is a convenient lift handle
- Non-marking, universal tread tires
- Variable-speed control setting up to 4.5 mph
- Sturdy, padded arm rests
- Formed, padded Clarin Seat with arms
- Slip-guard floor mat
- Angled footrest
- AmigoLift Power Seat (optional)
- Wide-Track duals with quick release pin
- Uncluttered control handle

SAFETY TIPS AND HELPFUL HINTS

Not bills, table

- Do not carry passengers.
- Vehicle is not suitable for street traffic.
- Do not back down an incline.
- Do not sit on the unit in a moving vehicle, even when it is secured.
- Always turn the power switch to the "OFF" position by placing the thumb control lever at 90 degree angle to the handle, and apply the parking brake when transferring onto or off the unit.
- Have AmigoLift Power Seat in lowest position when driving your unit.
- Do not operate your unit with the seat in the unlocked position.
- Always place thumb control lever at a 90 degree angle to the handle when not in motion, to turn off power switch.
- Always apply the parking brake before operating the AmigoLift Power Seat.

Wide track wheels.

WARNING

- DO NOT operate this unit until you have read the Owner's Manual.
- DO NOT exceed 250 lb. operator wt.
- DO NOT operate outdoors or on inclines without dual rear wheels.
- DO NOT operate on any incline over one (1) inch rise in twelve (12) inches of length.
- DO NOT make sharp turns at high speed or on inclines, or reverse direction abruptly.
- DO NOT back onto any surface change.

NOTE:

DO NOT operate the AmigoLift Power Seat without applying the parking brake first.

ASSEMBLY INSTRUCTIONS

Your Amigo Rear Wheel Drive unit is shipped to you practically ready for use. The unit is packaged in one box. The box contains the seat, main frame, wide-track duals, power cell charger, handle and two power cells. When unpackaging, check the contents of the box to be sure that nothing is missing. Remove the packing materials and all parts from the box (see Fig. 1).

Fig. 1

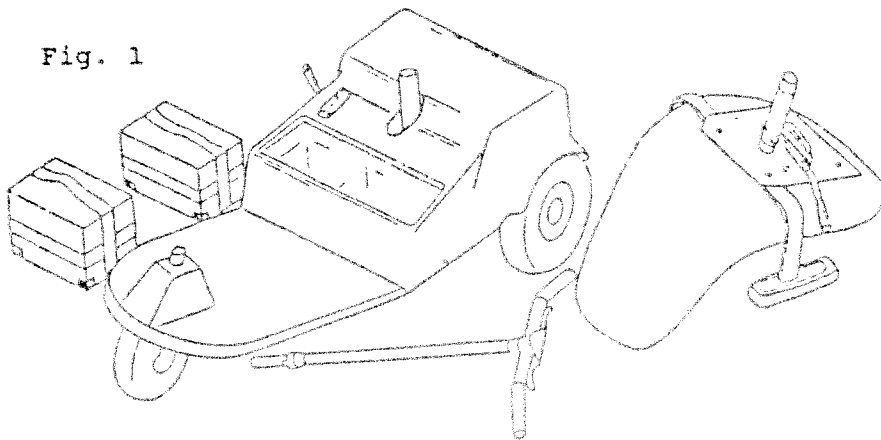

HANDLE

Insert the drive handle into the opening in the steering column. Place the thumb control lever at a 90 degree angle to the handle to turn power off. (see Fig. 4B)

see p 2 of Amigo Owner's Manual.

SEAT ASSEMBLY

1. Unlock the seat lock.
2. Insert the upper seat post into the opening in the lower seat post. Lower it until it sits on the lower seat post.
3. Turn (spin) seat around to make sure that it rotates freely 360 degrees.
4. To lock the seat in any position, pull the seat lock lever towards the rear of the seat.

SEAT HEIGHT ADJUSTMENT

NOTE: This information pertains to units that do not have a power seat lift.

The height of your conventional seat can be changed to better suit your need. To raise or lower your seat height, remove the nut and bolt that holds the seat collar in place on the seat post. Reinstall the bolt and nut in the new hole.

CAUTION: We strongly recommend that the seat lock be installed in either of the two holes positioned closest to the seat for best stability. If you want to put your seat higher than this, you must have Wide-Track Dual wheels on your unit at all times for added stability.

SEAT POSITIONING ADJUSTMENT

For added comfort and convenience, the seat can be moved closer to or farther away from the handle. To do this, the rear housing has to be removed and the lower seat post will have to be reversed. It will move the post approximately 3" to the front or rear, depending on which way it is turned.

NOTE:

We do not recommend using the seat in the forward position while using a bent handle. This could cause actuation of the thumb control while rotating the seat. Please exercise caution and turn the power off whenever the unit is not in motion or when transferring.

INSTALLATION AND REMOVAL OF WIDE-TRACK DUALS

*Make certain
to have 2 sets
ready in progress*

For added stability and traction, especially for use outdoors and on uneven terrain, you must use the Wide-Track Duals provided with your unit. The duals are easily removable for maximum maneuverability indoors.

To remove and re-install the outer Wide-Track Duals, use the following procedures:

REMOVAL OF WIDE-TRACK DUALS (Fig. 2)

Grasp the outer wheel with both hands while depressing the small button at the center of the quick release pin with your thumb. Pull the wheel toward you to remove.

INSTALLATION OF WIDE-TRACK DUALS (Fig. 3)

1. Remove center cap on the rear drive wheels.
2. Depress button in the quick release pin in the center of the outer dual wheel. Holding the dual wheel and pin, bring it toward the drive wheel.
3. Guide the bore coupling into the center hole of the inner drive wheel.
4. Turn the outer wheel so that the dual wheel coupler on the inside face lines up with the the bolt hole in the drive wheel casting.
5. Push the outer wheel in until the button of the quick release pin snaps out and the wheel cannot turn in either direction separate from the inner wheel.
6. Make sure that the wheel is securely attached try to pull out the dual wheel to insure it will not come off.

NOTE: To ease the removal and installation of the wide-track dual wheels, tilt the RWD to either side.

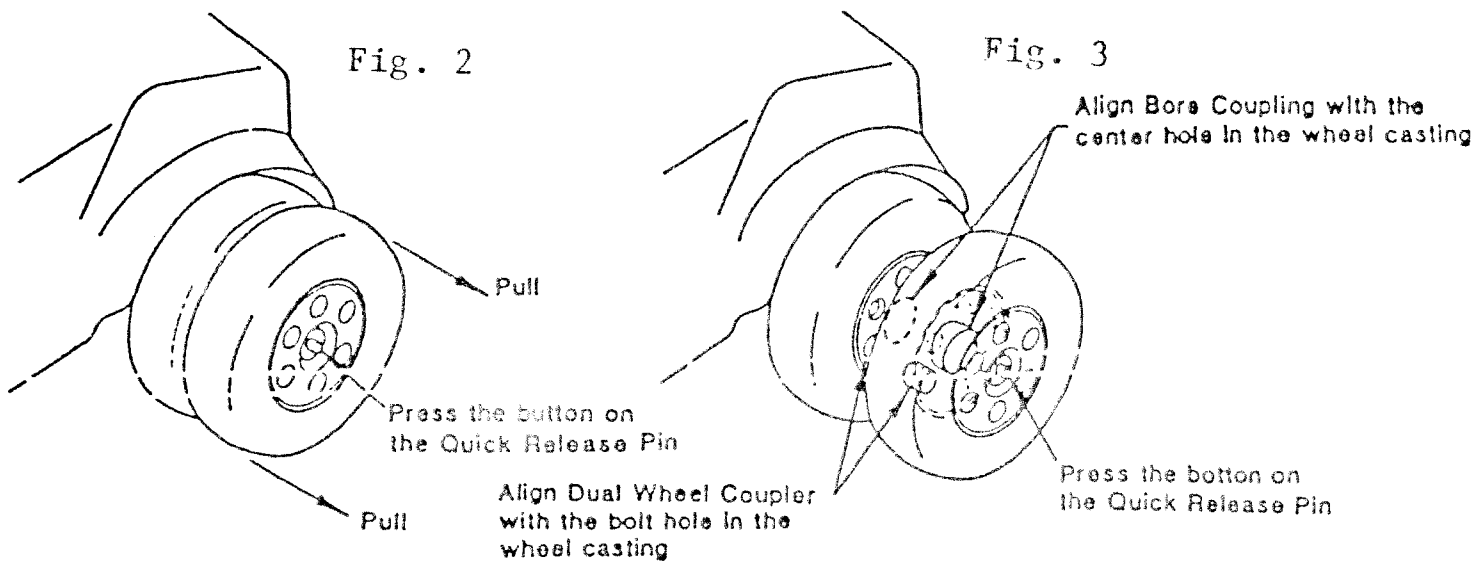

OPERATING THE UNIT

Become familiar with the controls and other items located on the rear cover. They include: Speed Limiting Control, Power Cell Charging Socket, and Seat/Drive Selector Switch (optional with AmigoLift Power Seat).

Placing the thumb control lever in the position shown in Fig. 4A will automatically turn ON the electric power switch. The red LED light on the front wheel cover will glow when the switch is on.

The switch can be left on during normal operation. However, it must be turned off when transferring to and from the unit, or when the unit is parked. Placing the thumb control lever in the 90 degree position shown in Fig. 4B will automatically turn OFF the electric power switch. This will prevent unauthorized use and reduce power cell drainage. THE SWITCH SHOULD BE IN THE "OFF" POSITION WHEN CHARGING POWER CELLS.

SPEED LIMIT ADJUSTMENT

Your unit is equipped with a variable-speed, solid state controller. The top speed of your unit can be regulated with a speed-limiting control located on the top of the rear cover. Slower speeds are recommended indoors or while learning to operate your unit. Higher speeds can be used as safety conditions permit.

- A. Turning the control knob clockwise increases the maximum speed up to 4-4.5 MPH.
- B. Turning the control knob counter - clockwise decreases the maximum speed to 2-2.5 MPH.
- C. Turn the knob to the speed setting most suitable for you. (Low setting for indoor use, faster setting for outdoor use.)

NOTE: For units equipped with a power seat lift, the "SEAT-DRIVE" switch must be in the "Drive" position.

DRIVING THE UNIT

To move forward, push the right side of the thumb control lever on the handle. Your unit will start and gradually accelerate to the desired speed. The further you push the thumb control, the faster your unit will go. When the thumb control lever is pushed all the way to the handle, you will be moving at the top, preselected speed. (See Fig. 4A)

maybe support of assembly instructions

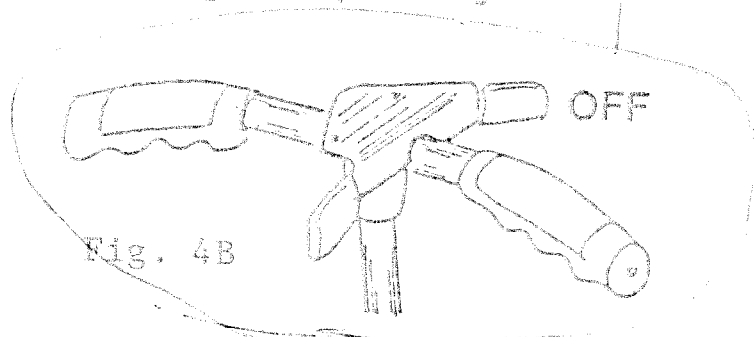

To stop your unit, release the thumb control lever. Your unit will gradually decelerate and come to a stop. Quick and smooth stops are made possible by the dynamic braking feature built into the controller.

To go in reverse, bring the unit to a stop, then push the left side of the thumb control lever or pull the right side toward you. You will find that the top speed in reverse is 40% slower than when in forward. This is for safety reasons.

For responsive, quick stopping, you can use pro-active braking. To activate the pro-active braking system, push the thumb control in the direction opposite to the direction of travel.

TURNING

Use caution when driving in forward or reverse and/or on uneven terrain.

CAUTION: SHARP TURNING OR REVERSING DIRECTION MAY CAUSE TIPPING.

Wide-Track Dual wheels improve stability and must be used for outdoor operation.

BRAKE LOCK

Your unit is equipped with a hand operated brake lock which will keep the unit from rolling when stopped. It also can be used as an emergency brake. The unit will stop automatically when you release the thumb control.

NOTE: DO NOT OPERATE YOUR UNIT WITH THE BRAKE LOCK ON. THIS WILL CREATE EXCESSIVE WEAR ON YOUR MOTOR, WHEELS AND BRAKE.

MANUAL PUSHING

Your unit is equipped with dynamic braking, which will make it difficult to push by hand. If it is necessary to push the Amigo RWD without power, and the dynamic braking causes undue load, remove both power cells, then remove rear cover. It is necessary to disconnect only one motor lead to relieve the dynamic braking. This will allow the unit to roll more easily.

AMIGOLIFT POWER SEAT OPERATION

Optional Equipment

The AmigoLift Power Seat electrically controls the height of the seat from 17 to 23 inches above the ground. To change height of the seat:

1. Apply parking brake.
2. Place "Seat/Drive" switch (located on top of rear cover) in the "Seat" position.
3. Push the right side of the thumb control lever to raise the seat and keep the switch depressed until your seat is at the desired height.
3. Push the left side of the thumb control to lower the seat to the desired height.

NOTE: A clicking noise when highest and lowest positions are reached is caused by a built-in slip clutch and is normal.

The speed of the seat lift is also regulated by the speed-limiting switch and can be changed as needed.

CAUTION: THE SEAT MUST BE IN THE LOWEST POSITION WHEN UNIT IS IN MOTION.

POWER CELL INFORMATION & CHARGING INSTRUCTIONS

Your unit is equipped with two 12 volt compact power cells providing 24 VDC electrical power. The power cells are rated at 24 ampere-hours; are starved electrolyte type; spill-proof and maintenance-free. The unique design permits you to quickly and easily remove and install each power cell without tools and without connecting wires to the power cell terminals. BE SURE THUMB CONTROL IS LIFTED TO THE "OFF" POSITION BEFORE REMOVING OR REPLACING POWER CELLS.

For maximum range and long life, it is recommended that you fully charge the power cell before using your unit. Partial charging will shorten the life of your power cell. When unit is not in use lift thumb control to prevent loss of battery charge. This will also shorten the life of the power cell.

GENERAL INFORMATION

1. The charger provided with the Amigo RWD can be left on overnight without overcharging.
2. This power cell charger has overload protection in the AC input and DC output circuits.

PREPARING TO CHARGE

1. Make sure the area around the power cell charger is well ventilated.
2. Make sure the power cell and charger connector terminals are clean.
3. Make sure the equipment has a 24 volt system.

CHARGER LOCATION

1. Locate charger as far away from power cell as DC cables permit.
2. Do not operate charger in a closed-in area or restrict ventilation in any way.
3. Do not set a power cell on top of a charger.
4. The charger can get very warm during normal operation. Do not set it on carpet or other surfaces sensitive to heat.

DC CONNECTION PRECAUTIONS

1. Make sure charger switch is turned "Off" or AC cord is unplugged BEFORE connecting or disconnecting charger.
2. Make sure charging plug is seated fully in power cell charging socket.

CHARGING INSTRUCTIONS

1. Review the safety and connection instructions.
2. Connect charger to power cell charging socket FIRST! (Fig. 5)
3. Connect AC cord to 120 volt AC outlet. (Fig. 6)
4. Turn charger switch "ON". The charger should be on and the ammeter should show the rate at which the power cell is charging. This initial rate may be higher or lower than 6 amps, depending on power cell condition and state of charge.

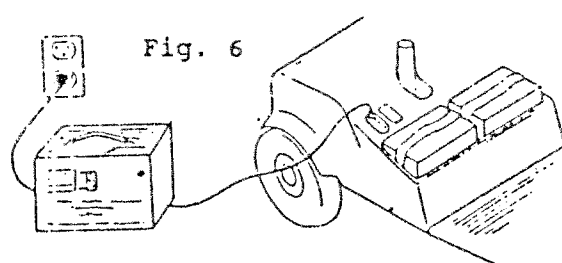
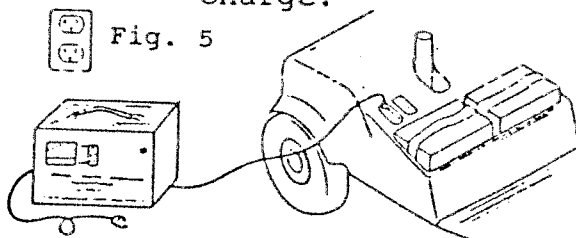

CHARGING GUIDELINES

The length of time to recharge will vary depending on the power cell size (Ampere-Hour Rating) and state of charge.

The following guidelines will help you determine when your power cell is charged.

1. The power cell is fully charged when the ammeter pointer has tapered off from its initial high charge rate and is fluctuating near the zero ampere mark.
2. If you know how many ampere-hours have been used, an approximate recharge time can be calculated by dividing that number by three (3) amps. For example, if the unit draws 4 amperes and it was used a total of 6 hours, 24 AH divided by 3 amps equals a recharge time of 8 hours.

NOTE: Use calculated recharge figures as a guide. The actual time could vary somewhat depending on the condition of your power cell and how accurately the power (AH) usage was figured.

DISCONNECTING THE CHARGER

ALWAYS SET THE CHARGER SWITCH TO "OFF" BEFORE DISCONNECTING THE CHARGE PLUG.

POWER CELL STATUS/POWER ON INDICATOR LIGHT

The indicator light, located on the top of the front wheel cover, will let you know:

1. WHEN THE POWER SWITCH IS "ON." - The indicator light will be on (red glow).
2. STATE OF CHARGE OF THE POWER CELL. - The light will go dim as the charge of the power cell is used up. After the unit has been operating, stop the unit and look at the LED light. It will be dim or out. If the light comes back up to a bright glow in about 30 seconds, the power cells still have a good level of charge. If it takes over 60 seconds to come up to bright glow or stays at dim glow, recharge at your earliest convenience.

CIRCUIT BREAKER

An automatic circuit breaker is located under the rear housing and attached to the positive (+) power cell terminal. Its purpose is to protect the wiring and the power cell against damage in the event of a short circuit. If the breaker opens, the unit will stop. Check for overloads or short circuits before continuing to operate.

TRANSPORTING YOUR RWD UNIT

CAR - Your unit can be readily transported in most conventional car trunks. It disassembles quickly and easily into several manageable parts: (See Fig.7)

1. Turn power "OFF" by removing the drive handle
2. Unlock the seat lock and remove the seat.

*Check if we have
candle turned to
off (7.7)*

3. Lift out the two power cells by the strap handles.
4. Lift the rear of your unit and set it on the edge of the trunk or on the floor of a van or a hatchback.
5. Grasp the front end and slide the unit into the vehicle.
6. Set the brake lock to keep the unit from rolling.
7. Place seat, handle and power cells in the trunk.

INSTRUKTION
245 دفتر
Amigo (PPA)

Fig. 7

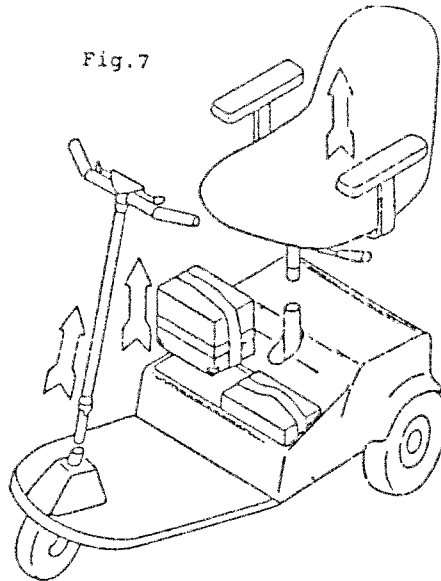

NOTE: For greater convenience and independence you may want to consider obtaining an Amigo Lift All. These accessories will assist you when loading your unit from or into the car.

AIRPLANE - Your unit is equipped with starved electrolyte type power cells, sealed and maintenance free. This type of power cell is non-spillable and is approved for use on airplanes and other common carriers. However, your power cells should be strapped securely to the base of your RWD. (A strap may be purchased through AMI.)

If traveling by air, at the time of making your reservation, notify the airline that you will be requesting "Escort" service for your vehicle. This will assure its pick-up and delivery at the boarding gate.

GROUND - Many types of public transportation have accommodations for wheeled devices like the Amigo RWD.

CAUTION: NEVER REMAIN SEATED ON YOUR UNIT DURING TRANSPORTATION BY ANY SOURCE.

Bdo-

MAINTENANCE INFORMATION

Your unit has been designed so that it requires only minimum maintenance. To increase dependability, please check the following for any possible problems:

Daily

- Maintain power cell charge as needed.

Monthly

- Check tire pressure. All pneumatic tires on rear wheels should be maintained at 40 psi. WARNING: DO NOT ~~EXCEED~~ ← *what's wrong* EXCEED 40 PSI.
- Check and clean power cell terminal connections as necessary.
- Clean upholstery, plastic and metal parts with a mild surface cleaner.
- Inspect belt for adequate tension and signs of wear.
- Check exposed fasteners to make sure they are on tight.
- Remove wide-track dual wheels and inspect mating parts of the dual wheels and drive wheels for signs of corrosion, wipe clean, and lightly coat mating parts with lubricating oil or grease.

Yearly

- Inspect front wheel bearings.
- Change drive belt.
- Have your authorized Service Center check over your unit completely.

NOTE: Frequency of above maintenance is based on average daily use.

SERVICE INFORMATION

If you follow the suggested maintenance schedule, your unit will give you years of dependable service. When you experience a service problem and have to write or call an Amigo Authorized Service Center, be sure to provide your unit's serial number. It is printed on the name plate of your unit. When you send in parts for repair, to give you efficient service, please include your unit's serial number and your address so we will know who sent them and what needs to be repaired.

AMIGOLIFT POWER SEAT CARE

Occasional inspection and simple maintenance (approximately every 1-2 months) should keep your AmigoLift Power Seat in great condition.

AMIGOLIFT LUBRICATION

1. Remove the seat.
2. Activate the seat lift to highest position.
3. Using a clean, dry cloth, wipe inner tube of of all accumulated grease, dirt, lint, etc.
4. Apply very thin coating of grease to inner tube, making sure you have covered the entire surface except for 1" at the top of the post.

NOTE: A container with grease has been supplied with the purchase of your AmigoLift. White lithium grease is recommended and additional quantities can be purchased at a local hardware store.

5. With seat off, operate the inner tube to it's highest and lowest positions several times. Stop at the lowest and wipe any accumulated grease away at the top of the outer tube.
6. Reinstall seat.

BEARING INSPECTION

Check front and rear wheel bearings periodically for roughness during rotation. Replace bearing if roughness is detected.

DIFFERENTIAL

Under normal conditions, your differential should operate problem free for the life of your unit. Do not attempt to service the differential yourself. If roughness or excessive noise occurs during normal operation of your unit, contact an Amigo Authorized Service Center.

CONTROLLER

Do not attempt to service the controller or related electronic components as you may void your warranty. In case of any irregularities, contact your Amigo Authorized Service Center.

REPLACING MOTOR DRIVE BELT

Tools: 15/16" socket wrench, 7/16" wrench.

NOTE: All reference to left or right is as if seated on the unit.

1. Remove seat from the unit.
2. Remove power cells.
3. Remove rear cover from the unit by pulling the sides and rear of the cover over the retaining pins and snaps and lifting it off.
4. Use a 7/16" wrench or socket and loosen the four bolts which hold the drive motor to the motor bracket (do not completely remove bolts).
5. After bolts have been loosened sufficiently, lower motor until the old drive belt can be removed from the motor and the differential pulleys.
6. Place something under the platform so the rear wheels are off the floor.
7. Remove the left Wide-Track Dual wheel or, if Wide-Track Duals are not used, remove the center cap from the left rear drive wheel.
8. Using a 15/16" socket, remove the differential axle nut located in the center of the left rear rim (do not lose washer).
9. After removing the left side differential nut, slide left rear wheel assembly off the axle.
10. Remove square key. Slide the shim washers and differential axle bearing off the axle.
11. Slide the differential assembly to the right of the unit until the left end of the differential axle clears the left side of the bearings support of the frame.
12. Remove old belt.
13. Place the new belt around the left end of the differential axle.
14. Place the left side of the differential axle through the left side bearing support of the frame.
15. Reposition drive belt on motor pulley.
16. Replace the shim washers and differential axle bearing back on the differential axle and into bearing support. Replace square key.
17. Replace wheel assembly onto differential axle and replace lock washer and axle nut. Tighten axle nut securely.
18. Replace the left rear dual wheel or the center cap on the left rear inner wheel if the dual wheels were not in place.
19. The drive belt should be tightened and the alignment of the pulleys checked by following the instructions described in the section, "Adjusting Belt Tension and Checking Pulley Alignment".

REPLACING REAR DRIVE WHEEL TIRE OR INNER TUBE

Tools: Two 7/16" wrenches, small screwdriver, two long shank screwdrivers, Phillips Screwdriver.

DISASSEMBLY:

1. Remove seat from the unit.
2. Remove power cells.
3. Remove rear cover. (See Replacing Motor Drive Belt).
4. Remove Wide-Track Duals from the same side of the unit as the tire which needs repairing or remove center cap from rim if the Wide-Track Duals are not in place.
5. Using the 15/16" socket wrench remove the axle nut, located in the center of the rim.
6. When the nut has been removed, slide the lock washer and the wheel assembly off the differential axle (be sure not to lose the differential axle key, spacer or shim washer next to the axle bearings).
7. If the tires are pneumatic and not foam filled, release any air pressure from the tire by depressing the needle on valve with the tip of a small screwdriver or similar instrument (be careful not to damage the valve). WARNING: DO NOT ATTEMPT TO DISASSEMBLE THE RIM BEFORE RELEASING ALL AIR PRESSURE FROM THE TIRE.
8. When all the air has been released, the rim can be disassembled and removed from the wheel assembly by removing the three bolts and nuts which hold it together. This requires two 7/16" sockets.
9. If the rim does not readily disassemble after removing bolts and nuts, use two long shank screwdrivers to gently pry the tire from the rim. Be careful not to damage the inner tube of the tire.

REASSEMBLY:

1. Release all air from the inner tube, if tires used are pneumatic.
2. Insert inner tube inside tire with valve stem pointing out.
3. Insert one rim half in tire inside diameter making sure the valve stem of the tube fits in the cutout on the inner face of the rim.
4. Put the two halves together (do not pinch inner tube).
5. Insert the three bolts through the rim, making sure the bolt heads are on the opposite side of the valve stem.
6. Place the locknuts on bolts and tighten the the assembly together
7. Inflate tire to 40 psi.

NOTE: Replace spacer and shim washers. Then re-insert drive key into keyway on axle if not still in place.

8. Place wheel assembly back on axle, aligning the keyway in the wheel with the key in the axle.
9. Put lock washer back on axle.
10. Replace axle nut and tighten securely. Do not overtorque the nut.

REPLACING TIRE OR INNER TUBE ON WIDE-TRACK DUALS

Tools: 7/16" socket wrench, small screwdriver, pair of pliers, long shank screwdriver.

DISASSEMBLY:

1. Remove Wide-Track dual wheels from unit.
2. Release all air pressure from tire by depress the needle on the valve with the tip of a small screwdriver or similar instrument, being careful not to damage the valve. **WARNING: ALWAYS RELEASE AIR PRESSURE FROM THE TIRE BEFORE DISASSEMBLING RIM.**
3. When all the air has been released, the rim can be disassembled by removing the three bolts and wheel coupling spacer with a 7/16" socket. It may be necessary to hold the spacer from turning with pliers.
4. If rim does not readily disassemble after removing bolts and wheel coupling spacers, use two straight head long shank screwdrivers to gently pry the tire from the rim being careful not to damage the inner tube of the tire.

REASSEMBLY:

1. Release all air left in the inner tube.
2. Insert inner tube inside tire.
3. Insert one rim half into tire, making sure the valve stem of the tube fits in the cut-out on the inner face of the rim.
4. Put the two halves together (do not pinch inner tube).
5. Insert the three bolts through the rim such that the bolt heads are on the opposite side from which the valve stem protrudes.
6. Replace wheel coupling spacer and tighten bolts securely with a 7/16" socket wrench.
7. Inflate tire to 40 psi.

ADJUSTING BELT TENSION AND CHECKING PULLEY ALIGNMENT

Tools: 7/16" socket, Phillips Screwdriver, 1/8" Allen Wrench

ADJUSTING BELT TENSION

1. Remove seat from the unit.
2. Remove rear cover. (See Replacing Motor Drive Belt).
3. The drive motor is mounted to the motor bracket by four bolts. Loosen the bottom two bolts so there is a 1/16" clearance between the screw head and the motor bracket. Loosen

- the two top bolts just enough to allow the drive motor to slide up & down.
4. With one hand under drive motor, lift it until belt is tight. Continue to hold motor in this position while tightening the two top mounting bolts only.
 5. Tighten the two bottom mounting bolts. This should bring the belt to the proper tension.

CHECKING PULLEY ALIGNMENT

1. To check pulley alignment, look at drive belt and note the position of the belt with respect to the pulleys. The belt should not hang over either edge of the pulley on the differential axle.
2. If belt does hang over either edge, loosen the set screw on the top of key located in pulley with a 1/8" Allen Wrench.
3. Move motor pulley on motor shaft as needed to eliminate belt over-hang on differential pulley.
4. Re-tighten set screw on motor pulley.
5. Run unit and recheck alignment.

LIST OF RWD TOOLS AND THEIR USES

1. 15/16 Socket Wrench: To remove the retaining nut on the inner wheel.
2. Allen Wrench: To remove screw from motor pulley.
3. Grease: For lubrication

pad things and
dash have had eyes

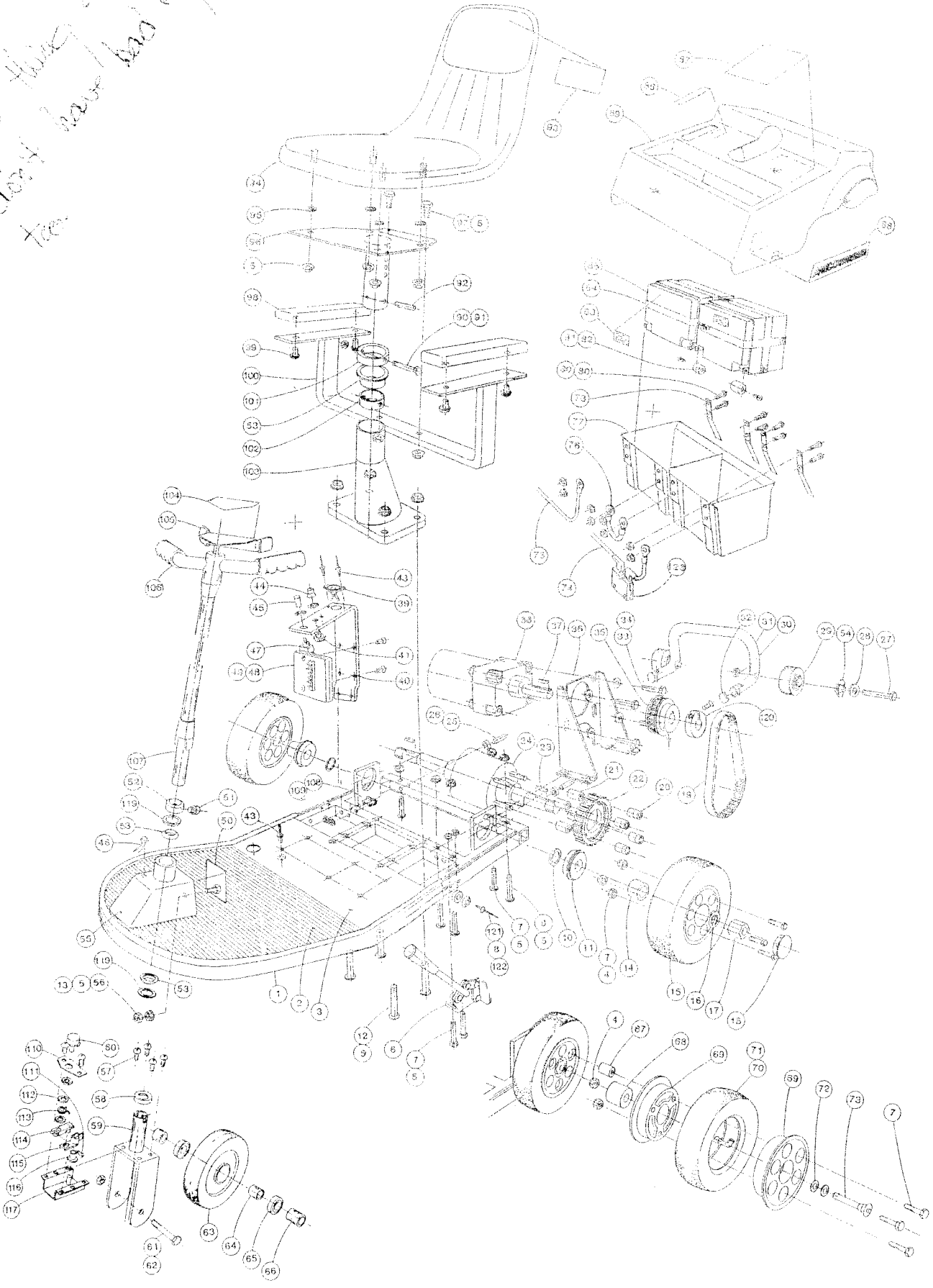

| REF# | ITEM# | AMIGO RWD PARTS LIST DESCRIPTION |
|------|--------|--|
| 1 | 300005 | BUMPER, RUBBER RWD |
| 2 | 300006 | FLOOR MAT, RWD |
| 3 | 300001 | WELDMENT FRAME |
| 4 | 111427 | NUT, HEX NY-LOCK 1/4-20 |
| 5 | 111387 | NUT, SERRATED FLANGE 1/4-20 |
| 6 | 300049 | BRAKE LOCK, RWD LEFT (Includes #5, #7) |
| | 300050 | BRAKE LOCK - RWD RIGHT (Includes #5, #7) |
| 7 | 1344 | SCREW, HEX HD. 1/4-20 x 1.5 |
| 8 | 5462 | SNAP STUD |
| 9 | 111307 | BOLT, HEX HD. 1/4-20 x 2.5 |
| 10 | 111207 | WASHER, SHIM .65 ID |
| 11 | 100150 | BEARING - WHEEL |
| 12 | 111295 | BOLT, HEX HD 1/4-20 x 2.0 |
| 13 | 111512 | NUT, HEX HD 1/4-20 |
| 14 | 300146 | SPACER-RWD REAR WHEEL 8/18/87 |
| 15 | 300143 | WHEEL ASSY-CAST PNEUMATIC REAR (Includes #12, #13, #69, #71, #70) |
| 16 | 5433 | WASHER-5/8 ID INT. TOOTH LOCK |
| 17 | 111542 | NUT-RWD SPECIAL AXLE |
| 18 | 300024 | CAP-RWD WHEEL COVER |
| 19 | 300010 | BELT-525-5M-15 |
| 20 | 5451 | NUT, 5/16-18 ALLEN NUT |
| 21 | 300093 | SPACER-RWD DIFFERENTIAL |
| 22 | 300092 | PULLEY-RWD DIFFERENTIAL |
| 23 | | SAME AS #37 |
| 24 | 300154 | DIFFERENTIAL ASSY-RWD 9/16/87 (Includes #20, #21, #22) |
| 25 | 111525 | PIN-3/16 x 2.0 GROOVE |
| 26 | 300096 | SPACER-NYLON |
| 27 | 111518 | SCREW-1/4-20 x 2.25 HEX HD |
| 28 | 1192 | WASHER 1/4 ID FLAT |
| 29 | 300008 | WHEEL-RWD STABILILITY |
| 30 | 111212 | NUT, HEX KEPS 1/4-20 |
| 31 | 300007 | TUBE-REAR BUMPER |
| 32 | 450009 | END CLOSURE-BUMPER |
| 33 | 111522 | SCREW-1/4-28 x .75 HEX HD CAP |
| 34 | 111305 | WASHER, FLAT .258 ID |
| 35 | 300012 | PULLLEY - RWD MOTOR |
| 36 | 300095 | BRACKET-MOTOR SUPPORT |
| 37 | 300013 | KEY-RWD MOTOR PULLEY |
| 38 | 300011 | MOTOR-RWD |
| 39 | 300041 | WIRE-RWD CHARGER PLUG |
| 40 | 300107 | BRACKET-ELECTRICAL |
| 41 | 300084 | POTENTIOMETER-HI/LO |
| 42 | 300080 | SWITCH-RWD ON/OFF |
| 43 | 111204 | RIVET-BLIND .125 x .38 |
| 44 | 300086 | KNOB-POTENTIOMETER |
| 45 | 341502 | SWITCH EXTENSION |
| 46 | | LED LIGHT-RWD (Front Housing) |
| 47 | 300109 | SWITCH-RWD POWER SEAT LIFT |
| 48 | 300156 | CONTROLLER-RWD (11/20/87) |
| 49 | 111532 | SCREW, #8-32 x .75 RD HD |
| 50 | 100013 | LABEL-OWNER'S |
| 51 | 111243 | SCREW, RETAINING COLLAR - AMIGO |

| | | |
|----|--------|--|
| 52 | 100031 | COLLAR-RETAINING |
| 53 | 300162 | BALL BEARING-STEERING - AMIGO |
| 54 | 111537 | WASHER-WAVE |
| 55 | 300003 | HOUSING-BLUE STEERING COLUMN (Includes #50) |
| | 300004 | HOUSING-BEIGE STEERING COLUMN (Includes #50) |
| 56 | 1180 | SCREW HEX HD 1/4-20 x 1.0 |
| 57 | 4750 | SCREW, TRUSS HD 10-32 x 3/8 |
| 58 | 100530 | SPACER-STEERING COLUMN |
| 59 | 300140 | WELDMENT-RWD FORK 8/18/87 |
| 60 | 300036 | POTENTIOMETER-ASSY RWD (Includes #110-#117) |
| 61 | 111321 | BOLT, HEX HD 3/8-24 x 3.75 |
| 62 | 111322 | NUT, HEX 3/8-24 x 3/8 ID WHEEL |
| 63 | 300034 | WHEEL ASSY-RWD GEL FRONT (Includes #64, #65) |
| 64 | 5178 | SPACER-CENTER AXLE |
| 65 | 300097 | BEARING-7/8 OD x 3/8 ID WHEEL |
| 66 | 300035 | SPACER-RWD OUTER AXLE |
| 67 | 300153 | SPACER-WHEEL COUPLING |
| 68 | 300155 | COUPLING-RWD WHEEL BORE |
| 69 | 300150 | WHEEL HALF-CAST DUAL/INNER REAR |
| 70 | 300019 | TIRE-GRAY 2.60-2.50-4 PNEUMATIC |
| | 300021 | TIRE-GRAY FOAM 2.80-2.50-4 |
| 71 | 450018 | TUBE-2.80/2.50 INNER |
| 72 | 111543 | WASHER-RWD PIN SHIM |
| 73 | 300152 | PIN-1.5 IN. DUAL WHEEL |
| 74 | | SAME AS #75 |
| 75 | 5425 | WIRE-RWD CONTROLLER TO PWR CELL |
| 76 | 2204 | WIRE ASSY |
| 77 | 300123 | HOLDER-DUAL POWER CELL |
| 78 | 300122 | CONTACT-POWER CELL |
| 80 | 1184 | SCREW, TRUSS 1/4-20 x .50 |
| 81 | 111451 | SCREW, BUT HD 10-32 x .50 |
| 82 | 111536 | TERMINAL CONTACT |
| 83 | 100012 | LABEL-POWER CELL |
| 84 | 300015 | HARNES-POWER CELL LIFTING |
| 85 | 300014 | POWER CELL-RWD |
| 86 | 300088 | DECAL-RWD SWITCH |
| 87 | 300089 | DECAL-RWD WARNING |
| 88 | 300090 | DECAL-RWD LOGO |
| 89 | 300158 | COVER ASSY-RH BEIGE REAR SNAP |
| | 300157 | " " RH BLUE " |
| | 300159 | " " LH BLUE " |
| | 300160 | " " LH BEIGE " |
| 90 | 111226 | BOLT, HEX HD 5/16-18 x 2.25 |
| 91 | 111227 | NUT, HEX KEPS 5/16-18 |
| 92 | 111228 | PIN, ROLL .125 x 1.125 |
| 93 | 100663 | LABEL-SEAT BACK |
| 94 | 270250 | SEAT-PADDED NILO (Includes #93, #95) |
| | 271250 | SEAT-PADDED NAUG (Includes #93, #95) |
| | 300051 | (Optional) SEAT-W/CUSHION FOLDING |
| 95 | 111369 | WAHSER, BLK PLASTIC THK .75 ID |
| 96 | 100670 | UPPER SEAT POST |
| | 100671 | UPPER SEAT POST-PSL (Includes #53, #90, #91, #92, #101, #102) |
| 97 | 111394 | BOLT, HEX HD SER 1/4-20 x 1.0 |

| | | |
|-----|--------|--|
| 98 | 210015 | ARM PAD-REG MOLDED (Includes #99) |
| 99 | 111245 | SCREW, BUT HD 1/4-20 x 3/4 |
| 100 | 210000 | ARMS-SOLID (Includes #5, #97, #98, #99) |
| 101 | 100690 | STEM COLLAR WITH BOLT & NUT (Includes #90, #91) |
| 102 | 100710 | BEARING-LOWER W/PIN (Includes #92) |
| 103 | 300053 | LOWER SEAT POST-RWD (Includes #4, #5) |
| 104 | 300076 | DECAL-RWD THUMB CONTROL |
| | 300077 | DECAL-RWD SINGLE THUMB CONTROL |
| 105 | 300078 | THUMB CONTROL-RWD (Includes #104) |
| | 300079 | THUMB CONTROL-RWD SINGLE HAND (Includes #104) |
| 106 | 100050 | GRIP-HANDLE |
| 107 | 300047 | HANDLE-RWD 21 STRAIGHT * |
| | 300048 | HANDLE-RWD 24 STRAIGHT * |
| | 300056 | HANDLE-RWD 21 W/2 BEND * |
| | 300057 | HANDLE-RWD 24 W/2 BEND * |
| | 300059 | HANDLE-RWD 21 STR. W/SNGL CNTL * |
| | 300060 | HANDLE-RWD 24 STR. W/SNGL CNTL * |
| | 300062 | HANDLE-RWD 21 W/2 W/SNGL CNTL * |
| | 300063 | HANDLE-RWD 24 W/2 W/SNGL CNTL * |
| 108 | 5196 | SCREW 10-32 x 1.5 HEX HD |
| 109 | 111234 | NUT, HEX KEPS 10-32 |
| 110 | 5251 | BRACKET-POTENTIOMETER SUPPORT |
| 111 | 5254 | SCREW #6-32 x .50 HSHC |
| 112 | 4270 | SPACER-RWD POTENTIOMETER |
| 113 | 5253 | SPRING-TORSION |
| 114 | 5255 | WELDMENT-DRIVEN LEVER |
| 115 | 5258 | WELDMENT-DRIVE LEVER |
| 116 | 5261 | BUSHING-DRIVE |
| 117 | 5262 | WELDMENT-POT SUPPORT LEVER |
| 118 | 300142 | WHEEL ASSY-CAST FOAM DUAL ** |
| | 300141 | WHEEL ASSY-CAST PNEUMATIC DUAL ** |
| 119 | 300153 | WASHER - RWD BALL BEARING |
| 120 | 300129 | CLAMP - COLLAR |
| 121 | 5463 | SPACER - NYLON |
| 122 | 5464 | RIVET - BLIND |
| 123 | 5482 | CIRCUIT BREAKER - 30 AMP |

* (Includes #104, #105)
** (Includes #67, #73)

RWD WIRING DIAGRAM WITH AMIGO LIFT SEAT

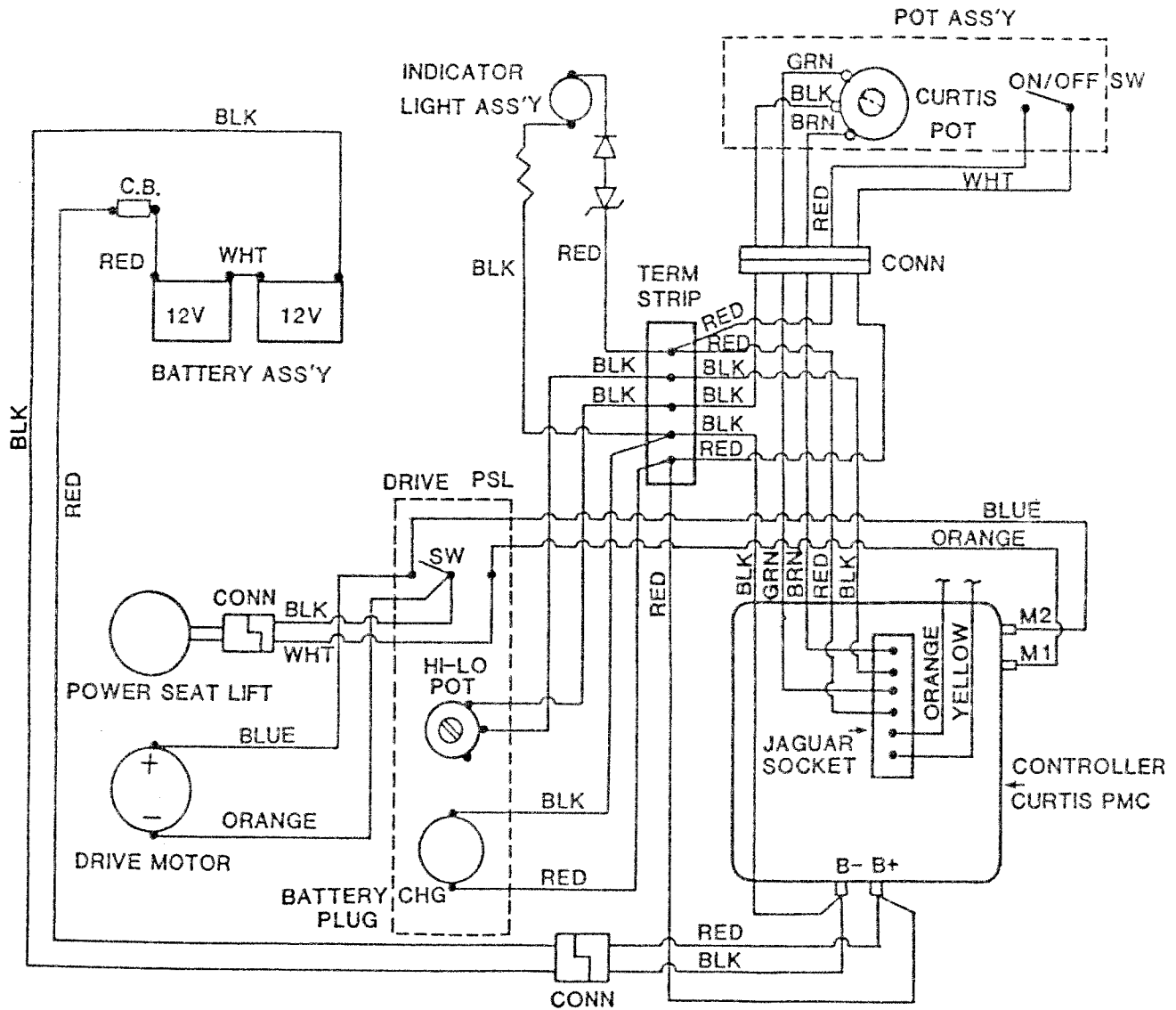

RWD WIRING DIAGRAM WITHOUT AMIGO LIFT SEAT

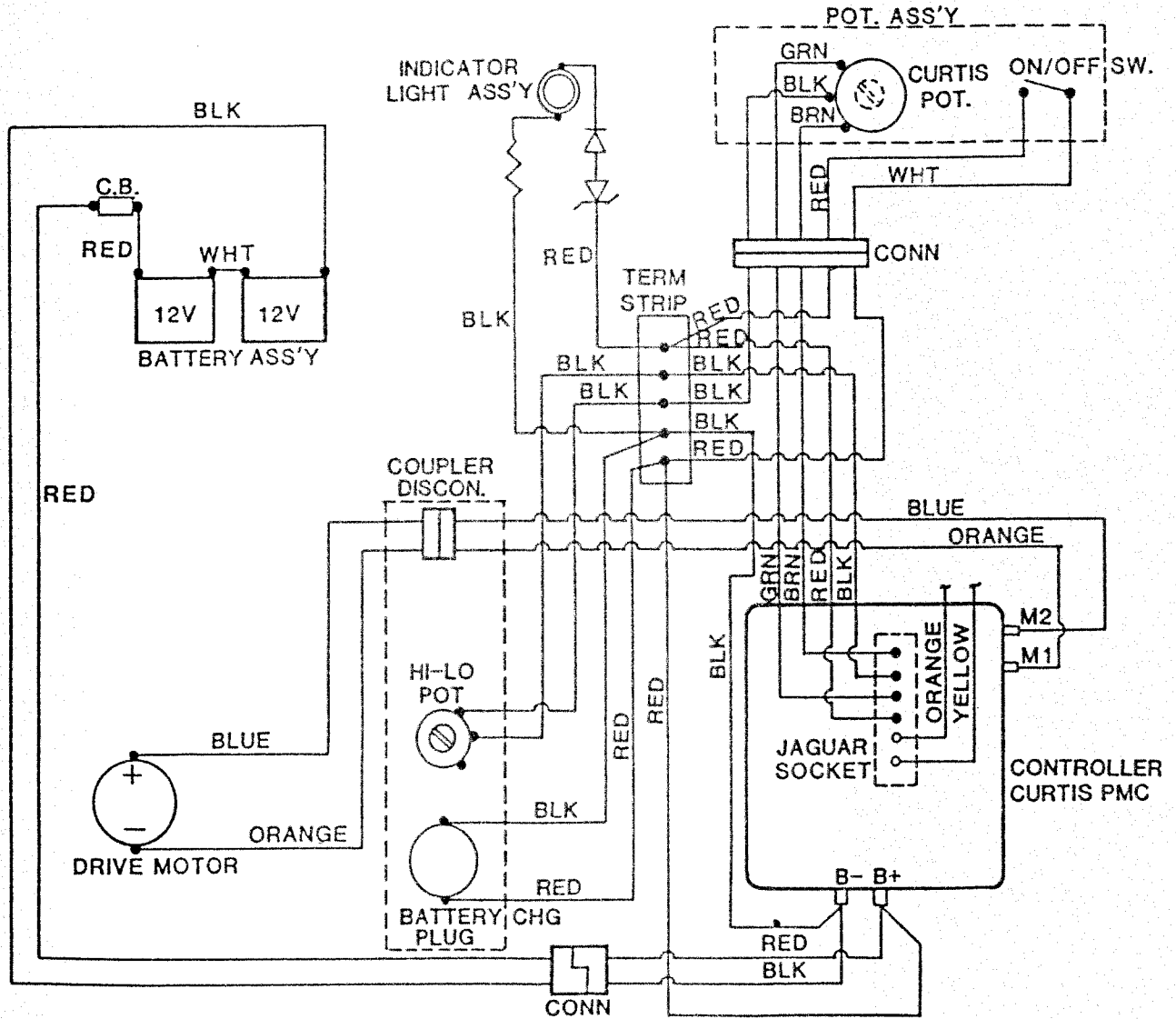

AMIGO RWD
LIMITED WARRANTY

Amigo Mobility International (AMI) warrants products it manufactures to the original purchaser.

1. Structural and mechanical components for Amigo Personal Mobility Aid - RWD are warranted against defects in materials and workmanship for five (5) years and limited to the following components: Floor mat, front and rear wheels, brake lock, seat lock casting, arms, arms pads, power seat lift component, handle parts, platform, fork, lower seat post and upper seat post.
2. Amigo Personal Mobility Aids are warranted against defects in materials and workmanship for five (5) years with replacement on a pro-rated basis and limited to the following components: Motor and vari-speed electronic Control boards, vari-speed potentiometer, differential.
3. Amigo battery chargers, bumper rubbers, housings and seats are covered against defects in materials and workmanship for one (1) year from the date of purchase.
4. The following wear components are warranted for six (6) months against defects in materials and workmanship: LED lights, electrical and mechanical switches.
5. Batteries supplied by AMI carry a six (6) month warranty.
* Using battery chargers not approved by Amigo will void battery warranty.
6. Use of this product by persons exceeding 250 lbs. is not recommended and voids this warranty.
7. AMI's obligation under this Warranty is limited to replacing or repairing, at its option or at the option of an Authorized Service Center, such products or parts that are returned/prepaid by the purchaser and are found to be defective. This warranty does not cover accidental damage, misuse, normal wear and tear, or use of Amigo products for other than personal purposes.

This Warranty gives you specific legal rights. You may also have other rights which vary from state to state.

Record your serial number

Service - Toll free: 1 (800) 248-9131



Amigo Mobility International
6693 Dixie Highway
Bridgeport, MI 48722-0402
(517) 777-0910
Call Toll-free: 1-800-248-9131